





SERVICE MANUAL



[IMPORTANT]

- ▶ Please read the manual carefully and keep it in mind before using this machine
- ▶ Put this manual within touch of your reference in anytime.

ISSUE DATE:Dec. 11, 2023

PRODUCT INFO	PART INFO	SUPPORT INFO	NEW PRODUCT INFO
			

※ QR(SUPPROT) - Leaflets, manuals, solution(error code,trouble shooting document, watch&solve)

PRECAUTIONS FOR USE

The following safety precautions are given throughout this manual. They must be strictly followed to protect those who install, use or maintain this product as well as to protect players, visitors and property.

For safety reasons.

- The following suggestions should be adhered to:



Disregarding could result in serious injury.



Disregarding could result in injury or product damage.

- The following graphic suggestions describe the types of precautions to be followed.



Indicates a care should be taken.



Forbidden.



Indicates a matter which must be performed.

- **Precautions to be followed:**

Certain procedures require a qualified in-shop maintenance person or industry specialist.

For such instructions, a qualified person must take care of the jobs.

- Otherwise an electric shock, machine trouble or a serious accident may result.
- Replacing the machine parts, inspecting and maintaining the machines and troubleshooting must be assigned only to a qualified in-shop maintenance person or industry specialist. This booklet gives instructions that hazardous jobs in particular must be handled by an industry specialist. Qualified in-shop maintenance person and industry specialist are defined as follows.

Qualified in-shop maintenance person

- A service staff shall have experience in operations of game machines. The staff shall be responsible for assembly, installation, inspection and maintenance of the machine.

Industry specialist

- An industry specialist must be engaged in designing, manufacturing, inspecting and servicing amusement machines. He or she must have an education in electrical, electronic and mechanical engineering and routinely maintain and repair amusement machines.

PRECAUTIONS FOR USE

WARNING

Be sure to consult an industry specialist when setting up, moving or transporting this product.

- This product should not be set up, moved or transported by any one other than an industry specialist.
- When installing this product, set the 4 leg levelers evenly on the floor and make sure that the product is installed stably in a horizontal position. Unstable installation may result in injury or accident.
- When installing this product, do not apply undue force on movable parts. Otherwise, injury and accident may result, or the product may be damaged.

The machine for indoor usage only does not install outside.



Do not set the game machine up near emergency exits.



Protect the game machine from:

- Rain or moisture.
- Direct sunlight.
- Direct heat from air-conditioning and heating equipment, etc..
- Hazardous flammable substances.
- Otherwise an accident or malfunction may result.



Do not place containers holding chemicals or water on or near the game machine.



Do not place objects near the ventilating holes.



Do not bend the power cord by force or place heavy objects on it.



Never plug or unplug the power cord with wet hands.



Never unplug the game machine by pulling the power cord.



CAUTION

Be sure to use indoor wiring within the specified voltage requirements. For extension cord, use the specified rating or more.

Be sure to use the attached power cord.

Never plug more than one cord at a time into the electrical receptacle.



Do not lay the power cord where people walk through.



Be sure to ground this product.



Do not exert excessive force when moving the machine.



For proper ventilation, keep the game machine 100mm(4") away from the walls.

Do not alter the system related dipswitch settings.

PRECAUTIONS FOR USE

WARNING

If there is any abnormality such as smoke, bad smell or abnormal noise being emitted from the machine, immediately turn OFF the main power switch and unplug the power cord from the receptacle to stop operating it. 

- Using the machine in abnormal conditions could result in fire or accidents.

In case of abnormality

1. Turn OFF the main power switch.
2. Unplug the power cord from the receptacle.
3. Contact your nearest dealer.

Do not leave the power cord plugged in improperly or covered with dust. 

- Doing so could result the power cord periodically.

CAUTION

Do not use this product anywhere other than industrial areas. 

- Using in a residential area or an area next to a residential area could affect signal reception of radios, television sets, telephones and etc..
- Do not give shock the surface of glass products.

- Please do not play this game if
 - When you do drinking;
 - When your physical condition is not normal;
 - When you are in pregnancy;
 - When you have on a pulse controller;
 - When you have recently experienced a cramp or fainting away while watching TV.
- Avoid excessive force/shock while playing/moving the game.
- While do games, pay attention to surrounding.

Do not plug or unplug the power cord with wet hands. 

In handling the power cord, follow the instructions below. 

- | | |
|---|--|
| • Do not damage the power cord. | • Do not modify the power cord. |
| • Do not bend the power cord excessively. | • Do not twist the power cord. |
| • Do not heat the power cord. | • Do not pull the power cord. |
| • Do not bind the power cord. | • Do not stand on the power cord. |
| • Do not sandwich the power cord. | • Do not drive a nail into the power cord. |

If the power cord or power plug becomes damaged, stop using the machine immediately and ask your nearest dealer to replace the parts.

*** Electromagnetic wave may cause unexpected noise from speaker.**

PRECAUTIONS FOR USE

WARNING

Be sure to turn OFF the main power switch and unplug the power cord from the receptacle before inspecting or cleaning the machine.



When replacing parts, be sure to use parts of the correct specifications. Never use parts other than the specified ones.



Opening inside the machine shall be done by machine specialist only as high electric current is being sent inside. For game machine with monitor, a care should be taken while opening its back door. If not, a damage to the inside parts or the monitor may occur.



If the sub power switch of the service panel is turned OFF without turning OFF the main power switch of the power supply unit, some parts in the units remain live. When opening the back door, be sure to turn OFF the main power switch and unplug the power cord from the receptacle.



Strictly refrain from disassembly and repair of parts which are not indicated in this manual, as well as settings and remodeling.



To clean the game machine, wipe it with a soft cloth dampened in a neutral detergent.

- Using thinner or other organic solvent or alcohol may decompose the material.
- Electrical shock or equipment failure could be caused by water entering the inside of the machine.

CAUTION

Components in the game are sensitive to vibrations and impact. Care should be used when moving and transporting the game machine.



Be sure not to let the machine tip over.

Before moving the machine, be sure to turn OFF the main power switch, unplug the power cord from the receptacle and remove the power cord from the machine.



Before moving take the machine, off the levelers and move it on the casters.

Avoid excessive force while moving the machine.

.....

PRECAUTIONS IN HANDLING

- When setting up, inspecting, maintaining, moving or transporting this product, follow the procedures and instructions set forth in this manual and perform such work safely.
- Do not set up, handle, inspect, maintain, move or transport this product under conditions equivalent to the condition of "WARNING" or "CAUTION" specified in this manual.
- If a new owner is to have this product as a result of transfer, and etc., be sure to give this manual to the new owner.

PRÉCAUTION D'EMPLOI

Les consignes de sécurité suivantes sont données dans ce manuel. Elles doivent être strictement suivies pour protéger ceux qui les installent. Utiliser ou entretenir ce produit pour la sécurité des utilisateurs, des visiteurs et des biens.

Pour des raisons de sécurité.

- **Les suggestions suivantes doivent être respectées:**

ATTENTION

Le non-respect peut entraîner des blessures graves.

PRUDENCE

Le non-respect peut entraîner des blessures ou des dommages au produit.

- **Les suggestions graphiques suivantes décrivent les types de précautions à prendre.**



Indique qu'attention est requise.



Interdit.



Indique que quelque chose doit être effectuée.

- **Les précautions à prendre :**

Certaines procédures exigent une personne de maintenance qualifiée en atelier ou un spécialiste de l'industrie. Pour ces instructions, une personne qualifiée doit prendre soin des travaux.

- Sinon, un choc électrique, un dysfonctionnement de la machine, ou un accident grave peut en résulter.
- Remplacement des pièces de machines, l'inspection et la maintenance des machines, et le dépannage doit être attribué qu'à une personne de maintenance qualifiée en atelier ou spécialiste de l'industrie. Cette brochure donne des instructions que les emplois dangereux, en particulier, doivent être traités par un spécialiste de l'industrie. La personne de maintenance qualifiée en atelier et le spécialiste de l'industrie sont définis comme suit.

La personne de maintenance qualifiée en atelier

- Un personnel de service doit avoir de l'expérience dans les opérations de machines de jeux. Le personnel est responsable pour l'assemblage, l'installation, l'inspection et l'entretien de la machine.

Le spécialiste de l'industrie

- Un spécialiste de l'industrie doit être engagé dans la conception, la fabrication, l'inspection et l'entretien des appareils d'amusement.
Il ou elle doit avoir une formation en génie électrique, électronique et mécanique, et de maintenir régulièrement et de réparer les appareils d'amusement.

PRÉCAUTION D'EMPLOI

ATTENTION

Si il y a une anomalie comme fumée, mauvaise odeur ou bruit anormal émis par la machine,  couper immédiatement l'interrupteur principal et débranchez le câble d'alimentation de la prise pour arrêter son fonctionnement.

- L'utilisation de l'appareil dans des conditions anormales peut provoquer un incendie ou un accident.

En cas d'anomalie

1. Mettez l'interrupteur principal sur ARRÊT.
2. Débranchez le câble d'alimentation de la prise.
3. Contactez votre revendeur le plus proche.

Ne pas brancher le câble d'alimentation incorrectement ou le laisser être recouvert de poussière. 

Cela pourrait nuire le câble d'alimentation.

PRUDENCE

Ne pas utiliser ce produit ailleurs que dans les zones industrielles. 

- L'utiliser dans une zone résidentielle ou d'une zone à côté d'un quartier résidentiel pourrait nuire à la réception des radios, téléviseurs, téléphones, etc.
- Ne donnez pas de choc à la surface d'un produit en verre.

- S'il vous plaît ne pas jouer à ce jeu.
 - Quand vous buvez;
 - Lorsque votre condition physique n'est pas normale;
 - Lorsque vous êtes dans une période de grossesse;
 - Lorsque vous avez un contrôleur d'impulsion;
 - Lorsque vous avez récemment subi une crampe ou évanouissement en regardant la télévision.
- Évitez une force excessive / un choc pendant la lecture / de déplacer le jeu.
- Quand vous jouez les jeux, faites attention aux alentours.

Ne pas brancher ou débrancher le câble d'alimentation avec les mains mouillées. 

Dans la manipulation du câble d'alimentation, suivez les instructions ci-dessous. 

- | | |
|--|---|
| • Ne pas endommager le câble d'alimentation. | • Ne pas modifier le câble d'alimentation. |
| • Ne pas plier le câble d'alimentation de manière excessive. | • Ne tordez pas le câble d'alimentation. |
| • Ne pas chauffer le câble d'alimentation. | • Ne tirez pas sur le câble d'alimentation. |
| • Ne pas lier le câble d'alimentation. | • Ne montez pas sur le câble d'alimentation. |
| • Ne pas prendre en sandwich le câble d'alimentation. | • Ne pas mettre un clou dans le câble d'alimentation. |

Si la fiche du câble d'alimentation ou est endommagé, cessez immédiatement d'utiliser la machine et demandez à votre revendeur le plus proche de remplacer les pièces.

PRÉCAUTION D'EMPLOI

ATTENTION

Assurez-vous de consulter un spécialiste de l'industrie lors de la mise en place, du déplacement ou le transport de ce produit.

- Ce produit ne doit pas être mis en place, déplacé ou transporté par une quelconque autre qu'un spécialiste de l'industrie.
- Lors de l'installation de ce produit, installez 4 niveleurs de pieds uniformément sur le sol et assurez-vous que le produit est installé de façon stable dans une position horizontale. Une installation instable peut entraîner des blessures ou un accident.
- Lors de l'installation de ce produit, ne pas appliquer une force excessive sur les pièces mobiles. Sinon, des blessures et des accidents peuvent y résulter, ou le produit peut être endommagé.

La machine pour une utilisation en intérieur uniquement, ne pas installer à l'extérieur.



N'installez pas la machine de jeu près des issues de secours.



Protéger la machine de jeu de:



- L'humidité ou la pluie.
- La lumière directe du soleil.
- La chaleur directe de la climatisation et du chauffage, etc...
- Des substances inflammables dangereuses.
- Sinon, un accident ou un dysfonctionnement.

Ne pas placer les récipients contenant des produits chimiques ou de l'eau sur ou près de la machine de jeu.



Ne placez pas d'objets à proximité des orifices de ventilation.



Ne pas plier le cordon d'alimentation par la force ou de placer des objets lourds au-dessus.



Ne jamais brancher ou débrancher le cordon d'alimentation avec les mains mouillées.



Ne jamais débrancher la machine de jeu en tirant le câble d'alimentation.



PRUDENCE

Veillez à utiliser le câblage intérieur selon les exigences de tension spécifiées. Pour une rallonge, utilisez la notation spécifiée ou plus.

Veillez à utiliser le cordon d'alimentation fourni.

Ne jamais brancher plus d'un cordon à la fois dans la prise électrique.



Ne pas poser le cordon d'alimentation où les gens marchent à travers.



Soyez sûr de mettre à la terre ce produit.



Ne pas exercer une force excessive lors du déplacement de la machine.



Pour une ventilation correcte, garder la machine de jeu 100mm (4 ") loin des murs.

Ne pas modifier les réglages des commutateurs DIP liées au système.

PRÉCAUTION D'EMPLOI

ATTENTION

Veillez à éteindre l'interrupteur d'alimentation principale et débranchez le cordon d'alimentation de la prise avant d'inspecter ou de nettoyer la machine. 

Lors du remplacement des pièces, veillez à utiliser une partie des spécifications correctes. Ne jamais utiliser de pièces autres que celles spécifiées. 

L'ouverture à l'intérieur de la machine doit être effectuée par le spécialiste de la machine seulement, comme le courant électrique élevé est transmis à l'intérieur. Pour la machine de jeu avec le moniteur, un soin doit être pris lors de l'ouverture de sa porte arrière. Si non, une détérioration des pièces à l'intérieur ou à l'écran peut se produire. 

Si l'interrupteur secondaire du panneau de service est éteint sans éteindre le commutateur d'alimentation principale de l'unité d'alimentation, certaines parties dans les unités restent sous tension. Lors de l'ouverture de la porte arrière, veillez à éteindre l'interrupteur d'alimentation principale et débranchez le cordon d'alimentation de la prise. 

Il est strictement conseiller de s'abstenir de démonter et de réparer des pièces qui ne sont pas indiqués dans ce manuel, ainsi que les paramètres et le remodelage. 

Pour nettoyer la machine de jeu, l'essuyer avec un chiffon doux imbibé avec un détergent neutre.

- L'utilisation plus mince d'un autre solvant organique ou de l'alcool peut décomposer le matériel.
- Un choc électrique ou une défaillance de l'équipement pourraient être causés par la pénétration de l'eau à l'intérieur de la machine.

PRUDENCE

Les composants de la machine de jeu sont sensibles aux vibrations et aux chocs. Il faut faire attention lors du déplacement et le transport de la machine de jeu. 

Veillez à ne pas laisser la machine se renverser.

Avant de déplacer la machine, veillez à éteindre l'interrupteur d'alimentation principale, débranchez le cordon d'alimentation de la prise et débranchez le cordon d'alimentation de la machine. 

Avant de déplacer la machine, la mettre hors des niveleurs et le déplacer sur les roulettes.

Éviter une force excessive lors du déplacement de la machine.

.....

PRÉCAUTIONS LORS DU MANIEMENT

- Lors de la mise en place, l'inspection, l'entretien, déplacement ou le transport de ce produit, suivez les procédures et les instructions énoncées dans ce manuel et effectuer ce travail en toute sécurité.
- Ne pas mettre en place, manipuler, inspecter, entretenir, déplacer ou transporter ce produit dans des conditions équivalentes à l'état de "ATTENTION" ou "PRUDENCE" spécifiée dans ce manuel.
- Si un nouveau propriétaire obtient ce produit à la suite d'un transfert, etc., soyez sûr de donner ce manuel au nouveau propriétaire.

CONTENTS

1	SPECIFICATION AND DIMENSION	
1)	DIMENSION	p2
2)	SPECIFICATION	p2
3)	STICKER LOCATION	p3
2	INSTALL INFORMATION	
	INSTALLATION SPACE, MAINTAIN PRODUCT FLATNESS, IMPORTANCE	p4
3	UNPACKING	
	PACKING LOCATION, NOTES ON UNPACKING, COMPONENTS	p4~5
4	INSTALL	
1)	HOW TO INSTALL(BILLBOARD)	p6
2)	HOW TO INSTALL(TOKEN & CARD SETTING)	p7
5	SETUP SETTINGS	
1)	PROGRAM SETTING	p8~10
2)	CLEAR MODE	p11
3)	BOOKKEEPING DATA	p11
4)	FACTORY SETTING	p11
5)	TEST MODE	p12~13
6)	PLAYFIELD-SETUP	p13
7)	GAME MODE	p13
6	MAINTENANCE	p14
7	SOLUTION	
1)	ERROR CODE	p15
2)	TROUBLESHOOTING	p16~29
	[E.31][E.41][E.51][E.52][E.61][E.62][E71][E72][E73][E81][E82][E91][Ec1][TOKEN SENSOR]	
8	EXPLODED VIEW	
▶	FULL DESCRIPTION	p30~31
▶	DETAILED EXPLANATION	p32~46
9	PCB CONNETCOR LOCATION	p47
10	BLOCK DIAGRAM	p48

1 SPECIFICATION AND DIMENSION

1) DIMENSION

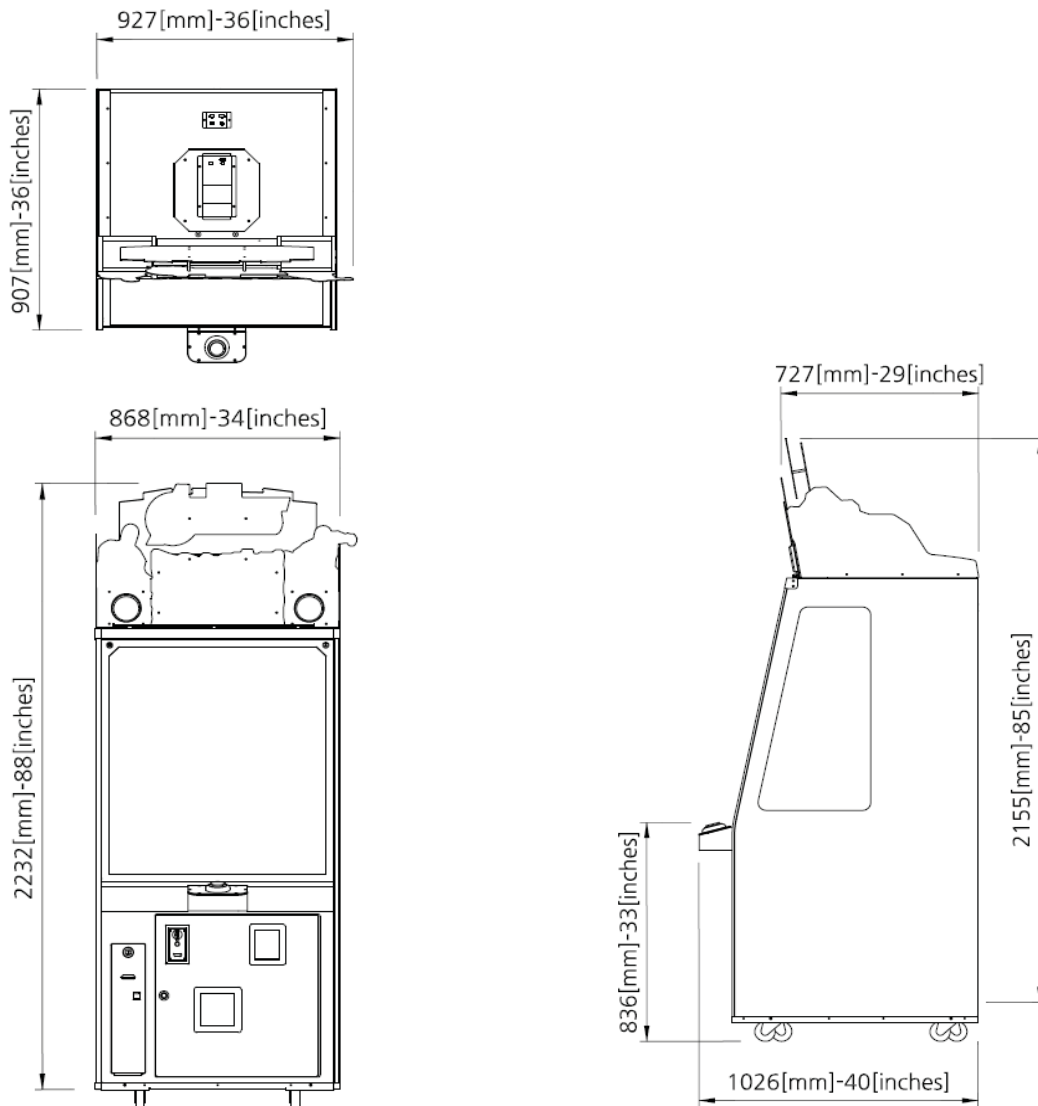



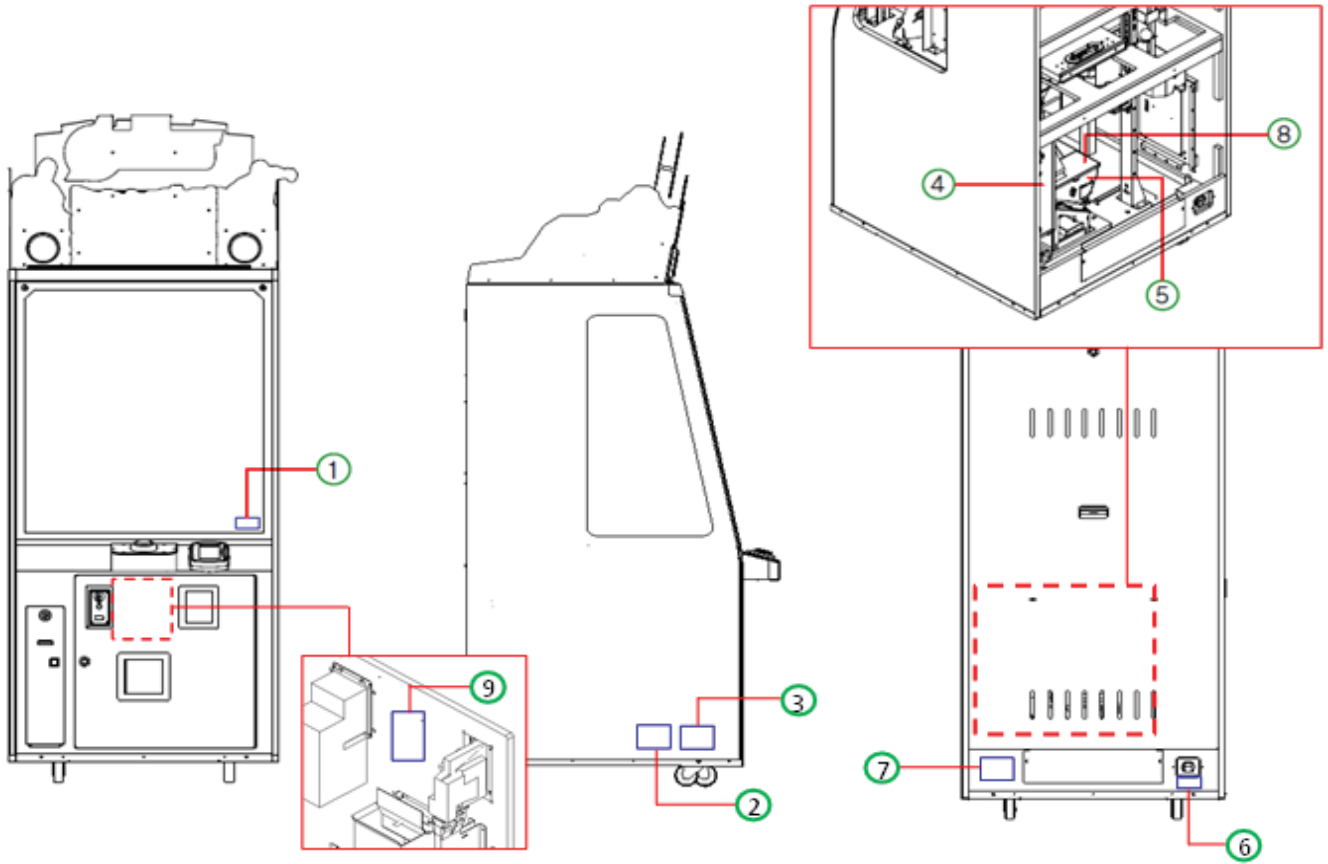

2) SPECIFICATION

ITEM	DETAILS	
VOLTAGE	AC 120V	AC 230V
FREQUENCY RANGE	60 Hz	50/60 Hz
CONSUMPTION	210 W	
INSTALL DIMENSION(W*D*H)	868 * 1026 * 2155 (mm) , 34 * 40 * 85 (inch)	
PACKING DIMENSION(W*D*H)	1150 * 980 * 2260 (mm) , 45 * 39 * 89 (inch)	
WEIGHT(kg), packing weight(kg)	250 kg, 270kg	
CERTIFICATION	ETL	-
※ NOTE : This product is a free bolt product.(AC 120-230V)		

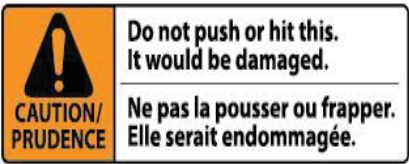
3) STICKER LOCATION

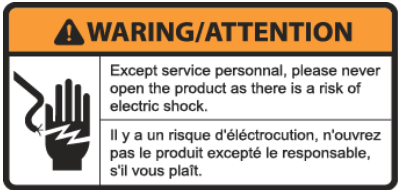
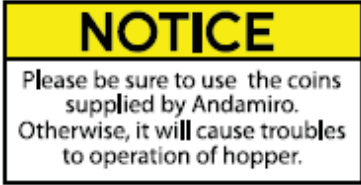

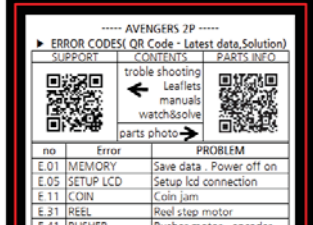
<p style="text-align: center;">▼ 1</p> 	<p style="text-align: center;">▼ 2</p> 	<p style="text-align: center;">▼ 3</p> 																		
<p style="text-align: center;">▼ 4</p> 	<p style="text-align: center;">▼ 5</p> 	<p style="text-align: center;">▼ 6</p> 																		
<p style="text-align: center;">▼ 7</p> <p style="text-align: center;">Certification Label</p>	<p style="text-align: center;">▼ 8</p> 	<p style="text-align: center;">▼ 9</p>  <table border="1" data-bbox="1101 2004 1369 2094"> <thead> <tr> <th>no</th> <th>Error</th> <th>PROBLEM</th> </tr> </thead> <tbody> <tr> <td>E.01</td> <td>MEMORY</td> <td>Save data . Power off on</td> </tr> <tr> <td>E.05</td> <td>SETUP LCD</td> <td>Setup lcd connection</td> </tr> <tr> <td>E.11</td> <td>COIN</td> <td>Coin jam</td> </tr> <tr> <td>E.31</td> <td>REEL</td> <td>Reel stop motor</td> </tr> <tr> <td>E.41</td> <td>REEL</td> <td>Reel motor error</td> </tr> </tbody> </table>	no	Error	PROBLEM	E.01	MEMORY	Save data . Power off on	E.05	SETUP LCD	Setup lcd connection	E.11	COIN	Coin jam	E.31	REEL	Reel stop motor	E.41	REEL	Reel motor error
no	Error	PROBLEM																		
E.01	MEMORY	Save data . Power off on																		
E.05	SETUP LCD	Setup lcd connection																		
E.11	COIN	Coin jam																		
E.31	REEL	Reel stop motor																		
E.41	REEL	Reel motor error																		

2 INSTALL INFORMATION

1) INSTALLATION SPACE

Maintenance zone & Play zone should have at
 ※ least 1500 mm(59 inch) * 2000mm(78inch)
 each

2) MAINTAIN PRODUCT FLATNESS

※ After installation is complete
 ※ 2-1 After securing space, adjust the 4
 adjuster so that the product is stably leveled.

3) IMPORTANCE

※ This product should be indoor use and out of
 direct sunlight.

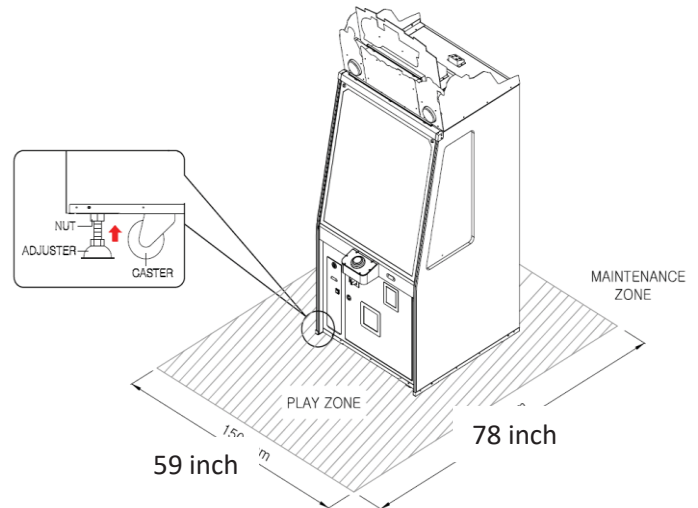

3 UNPACKING

1) PACKING LOCATION

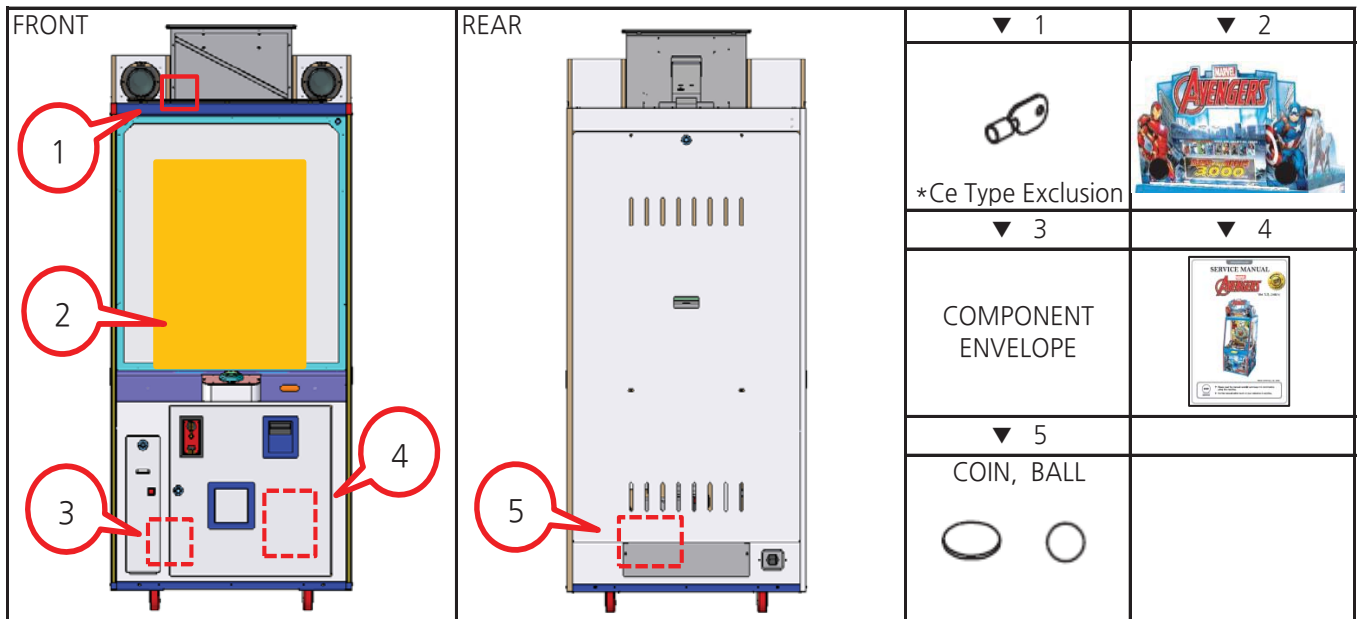



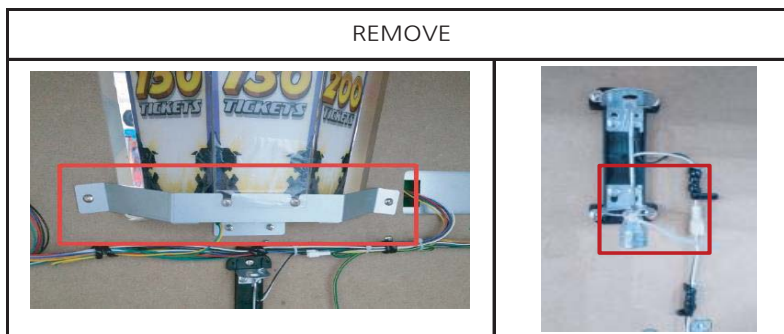











2) NOTES ON UNPACKING



3) COMPONENTS

no	PART NAME	Q'TY	SPARE	no	PART NAME	Q'TY	SPARE
1	AC POWER CORD	1		10	CARD *	1 box	
2	KEY 7001	2		11	MEDAL	1,100	
3	SCREW TH_NI M4x8L	16	8	12	BALL	18	
4	SCREW TH_M4x14L	4	8	13	CARD SETTING JIG *	1	
5	SCREW TH_NI M4x16L	8	4	14	CARD HEAVY PUSH BKT *	1	
6	SCREW M4x20L		6	15	COIN SELECTOR COVER BKT	1	
7	SCREW SEMS 5x16L	4	2	16	MANUAL	1	
8	NUT M4		10	17	BILLBOARD SUPT BAR-A	2	
9	WRENCH 2.5, 3, 4 mm	1					

* : Card version only

▼ 1	▼ 2	▼ 3,4,5	▼ 6	▼ 7	▼ 8
					
▼ 9	▼ 10	▼ 11	▼ 12	▼ 13	▼ 14
					
▼ 15	▼ 16	▼ 17			
					

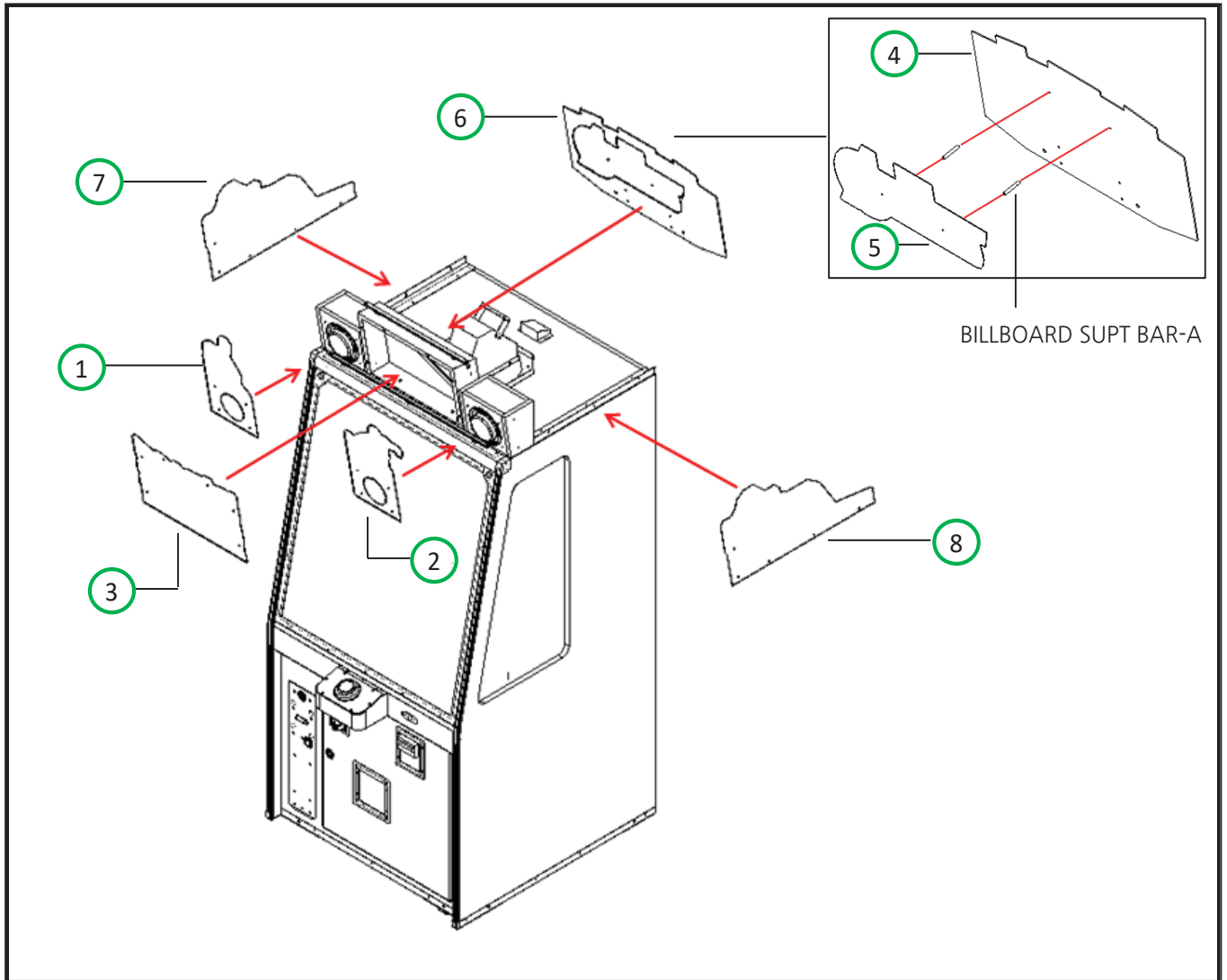

4 INSTALL

1) HOW TO INSTALL(BILLBOARD)

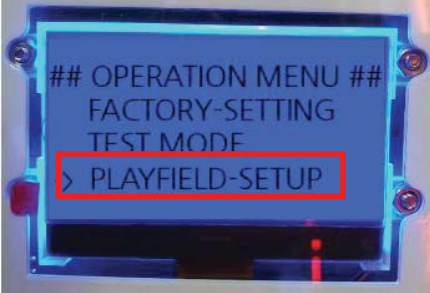

no	PROCESS	ITEM	Q'ty	BOLT	SPEC	Q'ty	
1	ASSEMBLE	SPEAKER BOX DECO COVER-L	1	TH_NI	4 * 16	4	
2	ASSEMBLE	SPEAKER BOX DECO COVER-R	1	TH_NI	4 * 16	4	
3	ASSEMBLE	B_MAIN FRONT COVER	1	TH_NI	4 * 8	8	
4	ASSEMBLE	B_DECO MAIN COVER-A	1	TH_NI	4 * 8	2	
5	ASSEMBLE	B_DECO MAIN COVER-B	1	TH_NI	4 * 8	2	
6	ASSEMBLE	B_DECO MAIN ASS'Y	1	SEMS	5 * 16	4	
7	ASSEMBLE	B_CABINET SIDE DEOCO ACRYL-L	1	TH_NI	4 * 8	3	
8	ASSEMBLE	B_CABINET SIDE DEOCO ACRYL-R	1	TH_NI	4 * 8	3	
9	POWER ON	This product is a free bolt product.(AC 120-230V)					

2) HOW TO INSTALL(TOKEN & CARD SETTING)

▼ 1	▼ 2	▼ 3
		
PUSHER	FRONT HOPPER	REAR HOPPER
▼ 4	▼ 5	▼ 6
		
▼ 7		
<div style="border: 1px solid black; padding: 5px; margin-bottom: 10px;">7-1</div> <div style="border: 1px solid black; padding: 5px; margin-bottom: 10px;">PUSHER BASE PANEL : BALL 6PCS</div> <div style="border: 1px solid black; padding: 5px; margin-bottom: 10px;">BALL SUPPLY :BALL 12PCS</div> <div style="border: 1px solid black; padding: 5px; width: fit-content;">7-2</div>		<div style="border: 1px solid black; padding: 5px; margin-bottom: 10px;">7-3</div> <div style="border: 1px solid black; padding: 5px; margin-bottom: 10px;">CARD DISPENSOR: CARD 146~147 PCS</div> <div style="border: 1px solid black; padding: 5px; margin-bottom: 10px;">PUSHER BASE PANEL : CARD 3 OR 4 PCS</div> <div style="border: 1px solid black; padding: 5px; width: fit-content;">7-4</div>

no	PROCESS	ITEM	Q'ty
1	SETTING	TOKEN : PUSHER PANEL – ABOUT 500 PCS	500
2	SETTING	TOKEN : FRONT HOPPER – ABOUT 300 PCS	300
3	SETTING	TOKEN : REAR HOPPER – ABOUT 300 PCS	300
4	SETTING	Enter SELECT Button -> OPERATION MENU -> PLAYFIELD-SETUP	
5	SETTING	PLAYFIELD-SETUP -> PUSHER TABLE SET.A	
6	SETTING	PUSHER TABLE SET.A -> START	
7-1	SETTING	BALL SETTING – PUSHER BASE PANEL	6
7-2	SETTING	BALL SETTING – BALL SUPPLY ASS'Y	12
7-3	SETTING	CARD SETTING –CARD DISPENSOR (*OPTION CARD VERSION)	146 or 147
7-4	SETTING	CARD SETTING –PUSHER BASE PANEL (*OPTION CARD VERSION)	3 or 4

5 SETUP SETTINGS

▶ SETUP BUTTON LAYOUT

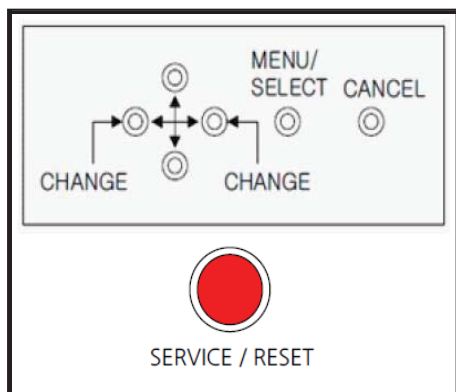

BUTTON	NOTE
UP/DOWN	MENU UP/DOWN MOVE
LEFT/RIGHT	CHANGE SETTING VALUE
MENU/SELECT	SETUP MENU MODE, SELECT AND PERFORM
CANCEL	EXIT
※CANCEL : PERFORM SETTINGS ONLY WHEN OPERATION OF BALL SUPPLY, REEL, BIG WHEEL, CARD, BRIDGE IS STOOPPED	
SERVICE/RESET : NORMALLY SERVICE IN, ABNORMAL(ERROR) - ERROR CLEAR	

▶ OPERATION MENU

PRESS MENU BUTTON. [MENU/SELECT BUTTON: TO ENTER]		
1	PROGRAM SETTINGS	SETUP MODE
2	CLEAR MODE	DELETE MODE
3	BOOKKEEPING DATA	VIEW GAME DATA
4	FACTORY SETTING	INITIALIZING TO FACTORY SETTING
5	TEST MODE	TESET MODE
6	PLAYFIELD-SETUP	PLAYFIELD-SETUP
7	GAME MODE	EXIT TO OPERATION OPTIONS

1) PROGRAM SETTING

1-1) PLAYS / CREDIT

LCD DISPLAY	DESCRIPTION	RANGE	DEFAULT					
			V_CARD			V_NO CARD		
			INT	NJ	W	INT	NJ	W
MINIMUM COIN		FREE, 1 ~ 10 (Increases by 1)	1	1		1	1	
1st.COIN ->_PLAYS	Setting number of plays per coin (SWIPE CARD) in ※ bonus for consecutive inputs	1 ~ 400 (Increases by 1)	12	2		12	2	
2nd.COIN ->_PLAYS			26	4		26	4	
3rd.COIN ->_PLAYS			42	6		42	6	
4th.COIN ->_PLAYS			60	8		60	8	
5th.COIN ->_PLAYS			75	10		75	10	

1-2) PLAYS / BIL

LCD DISPLAY	DESCRIPTION	RANGE	DEFAULT					
			V_CARD			V_NO CARD		
			INT	NJ	W	INT	NJ	W
1 BILL->_PLAYS	Setting number of plays per BILL or SWIPE	1 ~ 500 (Increases by 1)	12	7		12	7	
2 BILL->_PLAYS			26	14		26	14	
3 BILL->_PLAYS			42	21		42	21	
4 BILL->_PLAYS			60	28		60	28	
5 BILL->_PLAYS			75	36		75	36	
10 BILL->_PLAYS			175	75		175	75	
20 BILL->_PLAYS			400	150		400	150	

1-3) WHEEL LED SET

LCD DISPLAY	DESCRIPTION	RANGE	DEFAULT						
			V_CARD			V_NON CARD			CEC
			INT	NJ	W	INT	NJ	W	
W-LED01	 <p>Setting function and Score for each led lamp zone</p> <p>– Set type with left button "TOKEN", "TICKET", "PLAY", "BALL", "REEL", "CARD"</p> <p>– Set score with right button BALL, REEL, CARD are fixed at 1</p>	1 ~ 50 (Increases by 1)	TN15	TN 5		TN10	TN 5	TI3	
W-LED02			TN4	TN 1		TN6	TN 1	TN6	
W-LED03			TN8	TN 3		TN12	TN 3	TN12	
W-LED04			TN4	TN 1		TN6	TN 1	TN6	
W-LED05			TI10	TI 3		TN6	TI 3	TI2	
W-LED06			TN4	TN 1		TN6	TN 1	TN6	
W-LED07			TN8	TN 3		TN12	TN 3	TN12	
W-LED08			TN4	TN 1		TN6	TN 1	TN6	
W-LED09			TN15	TN 5		TN10	TN 5	TI3	
W-LED10			TN4	TN 1		TN6	TN 1	TN6	
W-LED11			TN8	TN 3		TN12	TN 3	TN12	
W-LED12			TN4	TN 1		TN6	TN 1	TN6	
W-LED13			CA1	TI 10		BA1	TI 10	IN1	
W-LED14			TN4	TN 1		TN6	TN 1	TN6	
W-LED15			TN8	TN 3		TN12	TN 3	TN12	
W-LED16			TN4	TN 1		TN6	TN 1	TN6	
W-LED17			TN15	TN 5		TN10	TN 5	TI3	
W-LED18			TN4	TN 1		TN6	TN 1	TN6	
W-LED19			TN8	TN 3		TN12	TN 3	TN12	
W-LED20			TN4	TN 1		TN6	TN 1	TN6	
W-LED21			TI10	TI 10		TN6	TI 10	TI2	
W-LED22			TN4	TN 1		TN6	TN 1	TN6	
W-LED23			TN8	TN 3		TN10	TN 3	TN12	
W-LED24			TN4	TN 1		TN6	TN 1	TN6	

1-4) REEL SET

LCD DISPLAY	DESCRIPTION	RANGE	DEFAULT						
			V_CARD			V_NO CARD			CEC
			INT	NJ	W	INT	NJ	W	
REEL#1	Setting function and score for each reel zone  7 - Set type with left button 1 ~ 100 (Increases by 1) - Set score with right button	TOKEN=TN, TICKET=TI	TI50	TI15	TI50	TI15	TI12		
REEL#2			TN20	TN10	TN20	TN10	TN20		
REEL#3			TI30	TI20	TI30	TI20	TI8		
REEL#4			TN30	TN15	TN30	TN15	TN30		
REEL#5			TN35	TN18	TN35	TN18	TN35		
REEL#6			TI20	TI10	TI20	TI10	TI5		
REEL#7			TN25	TN25	TN25	TN25	TN25		

1-5) BIG WHEEL SET

LCD DISPLAY	DESCRIPTION	RANGE	DEFAULT						
			V_CARD			V_NO CARD			CEC
			INT	NJ	W	INT	NJ	W	
BIG_WHEEL#1	Setting contents of winning by zone at big wheel 1  8 100 ~ 5000 * CEC 0 ~ 5000	100 ~ 5000 * CEC 0 ~ 5000	500			1000			250
BIG_WHEEL#2			100			120			30
BIG_WHEEL#3			150			250			65
BIG_WHEEL#4			130			200			50
BIG_WHEEL#5			200			500			125
BIG_WHEEL#6			120			150			35
BIG_WHEEL#7			180			300			75
BIG_WHEEL#8			80			100			25

LCD DISPLAY	DESCRIPTION	RANGE	DEFAULT						
			V_CARD			V_NO CARD			CEC
			INT	NJ	W	INT	NJ	W	
CHECKER BONUS	Setting bonus tickets when making goal into main checker at main game	0 ~ 50	0			0			0
TICKET / BALL	Dispensing tickets when ball drops	0 ~ 20							
BALL/TOKENS	Dispense one ball according to total number of tokens (Tokens shoot by the player and tokens	1 ~ 500	80			70			70
[OPTION] CARD/TOKEN	Dispense one card according to total number of tokens (Tokens shoot by the player and	10 ~ 500	200			200			200
PAYOUT	Setting number of tickets per swipe	10 ~ 100	40			60			6
MERCY TICKET	Setting number of tickets to be dispensed in case of failuer	0 ~ 10	0			0			0
FIXED TICKET	-	0 ~ 50	*DEFAULT : 0						
TICKET SCORE	Setting ticket ratio per score , None : Automatically reducing ticket counts without dispensing tickets	NONE, 1/1, 1/2, 1/3, 1/4	1/1			1/1			1/1
ATTRACT VOLUME	Use of demo sound and setting volume	OFF, 10 ~	60			60			60
LAMP SPEED	Lamp wheel movement speed	1 ~ 10	X	3	X	3	X		
LAMP REVERSE	Lamp wheel forward/reverse rotation setting	OFF, ON	X	OFF	X	OFF	X		
REEL STOP TIME	AT : Automatic stop without button input	1 ~ 60	X	10	X	10	X		
SAVE AND EXIT	SAVE AND EXIT :Select button - [YES] or [NO]								
CANCEL AND EXIT	Cancel and exit								

2) CLEAR MODE : Game data and bookkeeping data can be deleted

LCD DISPLAY	DESCRIPTION	EXECUTION
CREAR TICKETS	Delete remaining tickets to be dispensed now	By pressing select button, perform by moving the cursor to [YES] or [NO]
CLEAR PLAYS	Delete remaining plays(credits) and bonus ball (Delete all cards & tokens to be dispensed)	
CLEAR DATA	Delete all game data and bookkeeping data including credits and tickets	
EXIT	Exit	

3) BOOKKEEPING

LCD DISPLAY	DESCRIPTION	LCD DISPLAY	DESCRIPTION
--- COIN IN --- 0 --- BILL IN --- 0	Number of coins inputs Number of bill inputs	--- REEL WIN --- REEL#4 : 0 REEL#5 : 0 REEL#6 : 0	Number of Reel wins
--- SERVICE IN --- 0 GAME PLAY SHOT 0	Number of service inputs Number of token launch	--- REEL WIN --- REEL#7 : 0 TOTAL : 0	Number of Reel wins
BONUS COIN SHOT 0 6 BALL COLLECTION 0	Number of service inputs Number of token launch	-T382-BIG WHEEL WIN - REEL#1 : 0 REEL#2 : 0 REEL#3 : 0	Number of BIG WHEEL wins
--- TICKET OUT --- 0 CHECKER GOALIN 0 %	Ticket out quantity Percentage of checker pass	- BIG WHEEL WIN - REEL#4 : 0 REEL#5 : 0 REEL#6 : 0	Number of BIG WHEEL wins
--- CARD OUT --- 0	Number of card dispensing	- BIG WHEEL WIN - REEL#7 : 0 REEL#8 : 0 TOTAL : 0	Number of BIG WHEEL wins
--- REEL WIN --- REEL#1 : 0 REEL#2 : 0 REEL#3 : 0	Number of Reel wins	--- VER INFO --- AVENGERS ONE Ver._._ MM. DD. YYYY	Display version information and program compilation data
CANCEL BUTTON : EXIT			

4) FACTORY - SETTING : Initialize to factory setting

※ CAUTION : Clear all data and set to default value of game set p)

5) TEST MODE

LCD DISPLAY	COMPOSITION	DESCRIPTION
INPUT TEST	00000000	Input signal test TICKET FND & TOKEN FND : Display of input signal status
		1.BALL SUPPLY SENSOR 2.BALL SUPPLY SW 3.REAR HOPPER SENSOR 4.FRONT HOPPER SENSOR 5.CONVEYER ENCODER 6.SHOT BUTTON 7.BILL SENSOR 8.COIN SENSOR
		1.BRIDGE FRONT SENSOR 2.BRIDGE REAR SENSOR 3. FRONT HOPPER FULL SENSOR 4.BALL SENSOR 5.CARD SENSOR 6.TICKET BUTTON 7.TICKET SENSOR 8.SERVICE BUTTON
		1.BUTTON TILT SENSOR 2.BODY TILT SENSOR 3.TOKEN SENSOR 4.TOKEN SENSOR1 5.REEL HOME SENSOR 6.WHEEL HOME SENSOR 7.WHEEL HOLE ENCODER 8.PUSHER SENSOR
FND & LED OFF	ON/STEP/OFF	FND & LED operation test Check operation status PLAYS FND: Display of sensor status
WHEEL MOTOR TEST TEST OFF	OFF/ON	Wheel operation status PLAYS FND : Display of sensor stauts
PUSHER MOTOR TEST TEST OFF	OFF/ON	Pusher motor operation test PLAYS FND : Display of sensor stauts
FRONT HOPPER TEST TEST 3 OFF	OFF/ON	Front elevator hopper operation test When performed, it automatically stops after discharging 3 medals PLAYS FND : Display of sensor status and quantity
REAR HOPPER TEST TEST 3 OFF	OFF/ON	Rear elevator hopper operation test When performed, it automatically stops after discharging 3 medals PLAYS FND : Display of sensor status and quantity
BALL SUPPLY TEST TEST OFF	OFF/ON	Ball supply operation test When performed, it automatically stops after discharging one if there is a ball PLAYS FND : Display of sensor status
[OPTION] TOKEN BRIDGE TEST TEST OFF	OFF/ON	Token bridge motor test PLAYS FND : Display of sensor status
CARD DISPEN TEST TEST OFF	OFF/ON	Card dispenser test When performed, it automatically stops after discharging one card PLAYS FND : Display of sensor status and quantity
[OPTION] CONVEYER TEST TEST OFF	OFF/ON	Conveyer test PLAYS FND : Display of sensor stauts
TICKET MACHINE TEST TEST 3 OFF	OFF/ON	Ticket dispenser test When performed, it automatically stops after discharging 3 tickets if there are tickets PLAYS FND : Display of sensor status and quantity
COIN TEST TEST OFF	OFF/ON	Coin selector inhibit test Check whether power of coin selector is thrned off by performing PLAYS FND : Display of sensor status
COUNTER TEST COIN TICKET 0 0	Display of counter signal	Counter test Left button : coin counter test, Right button : ticket counter test

REEL TEST TEST OFF	OFF/ON	Reel test When performed, it works PLAYS FND : Display of sensor status
BIG WHEEL TEST TEST OFF	OFF/ON	Big wheel test When performed, it works PLAYS FND : Display of sensor status
SOUND TEST	OFF/2~93	Automatic sequential sound playback with select button Play sound using the left and right button
BALL IN TEST 1P : 0 ER 2P : 0 ER	Number of ball detections	ER display in case of sensor error TICKET FND : Number of ball detections PLAYS FND : Error display
EXIT	Test mode exit	

6) PLAYFIELD - SETUP

When installing the machine initially, fill supplied medal to the front hopper and proceed with pusher table set A

LCD DISPLAY	DESCRIPTION
PUSHER TABLE SET.A	: Test the product until the medal is fired 1,000 times. : When installing the machine initially, pusher table setting(Perform by select button) 1.Fill up 1,100 medals into front hopper 2.Select the relevant mode 3.The wheel spins and stops and then automatically fires 1,000 medals 4.When all 1,000 medals are fired, it automatically stopped and pusher table medal setting is completed
PUSHER TABLE SET.B	: Test the product until the medal is fired 3,000 times.
PUSHER TABLE SET.C	: Test the product until the medal is fired 1,000 times.
EXIT	Exit

7) GAME MODE return to the game node

6 MAINTENANCE

1) Precautions for turning on the power.

: When it is newly turned on after power is turned off, the power must be turned on after 10 seconds.

2) When installing the device

: Connect the device with a ground outlet to which fg is connected.

3) Main board management.

: Dust removal on the main board will be carried out once a month.

4) Basic product management : Clean it regularly

5) This product should only be used for indoor use

7 SOLUTION

1) ERROR CODES

PAGE : Solution Page N/O of Manual

AVENGERS 1P

CODE	ERROR	NOTE	PAGE
E.01	BACKUP MEMORY	Save data problem. Power off on	
E.05	SETUP LCD ERROR	Setup lcd connection problem	
E.11	COIN ERROR	Coin jam problem	
E.31	REEL ERROR	Reel step motor defects	19
E.41	PUSHER ERROR	Pusher motor problem or pusher encoder problem	21
E.51	WHEEL ERROR	Wheel motor problem ,encoder problem	23
E.52	BIG WHEEL ERROR	Big wheel step motor problem or photo sensor defects	24
E.61	F_ELEVATOR HOPPER	Front elevator hopper or coin jam	26
E.62	R_ELEVATOR HOPPER	rear elevator hopper or coin jam	28
E.71	BALL SUPPLY	Problem of ball supply motor or photo sensor	30
E.72	BALL SUPPLY	limit switch defects	32
E.73	BALL IN SENSOR	Ball in sensor	33
E.81	TOKEN BRIDGE	motor problem , front encoder sensor	34
E.82	TOKEN BRIDGE	motor problem , rear encoder sensor	34
E.91	CONVEYER ERROR	(MEDAL ROLLER)Motor or encoder sensor problem	37
E.c1	CARD DISPENSER	Card empty ,card jam,card dispensor	39
	TOKEN SUCCESS SENSOR	Token success sensor	41
E.t1	TICKET ERROR	No tickets or ticket jam	
TILT1	Upper backside	When shaking the machine but will be cleared after 15 seconds	
TILT2	1P Button panel		

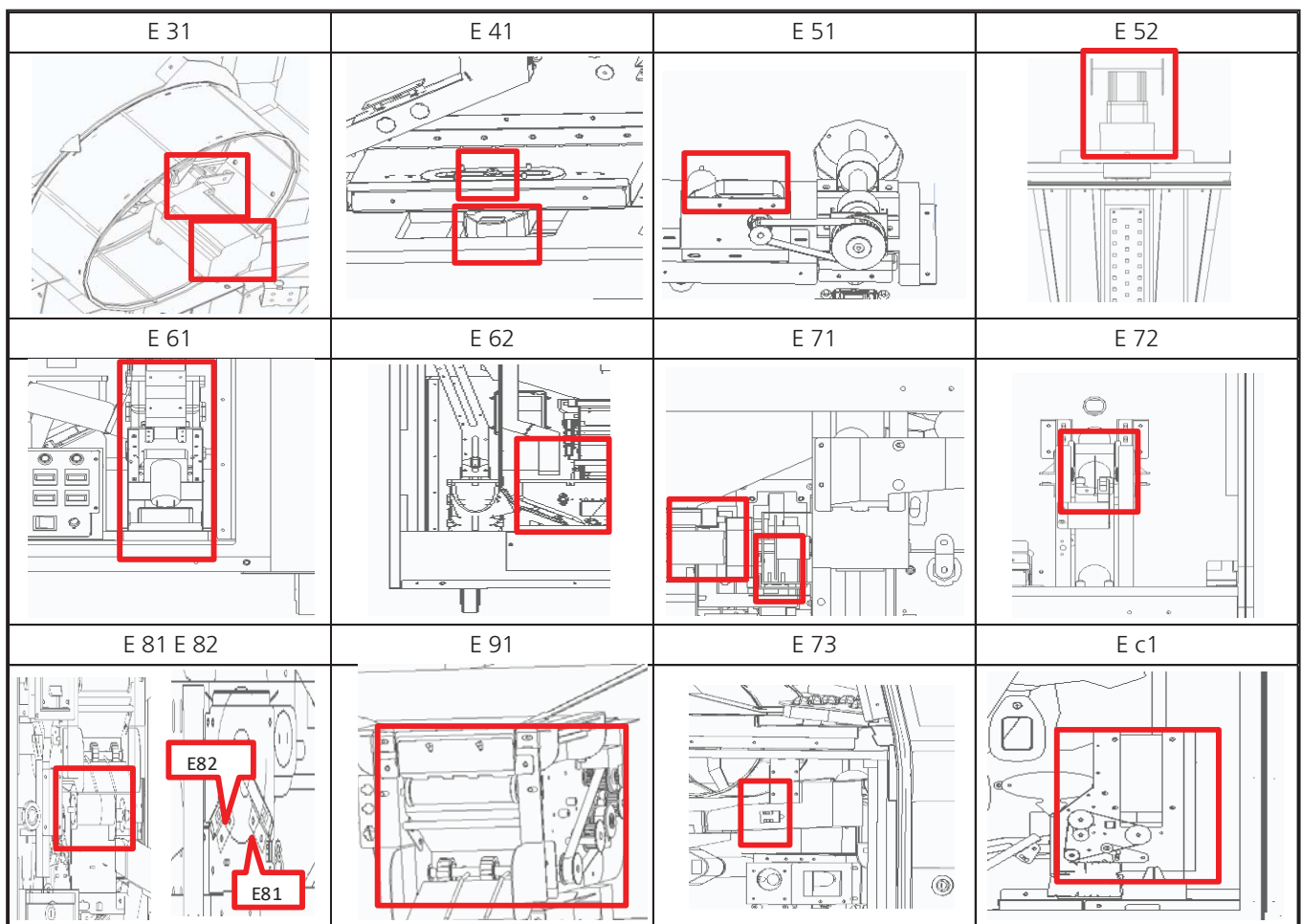

2) TROUBLESHOOTING

1) REEL MOTOR ERROR [E.31], REEL SENSOR ERROR [E.31]

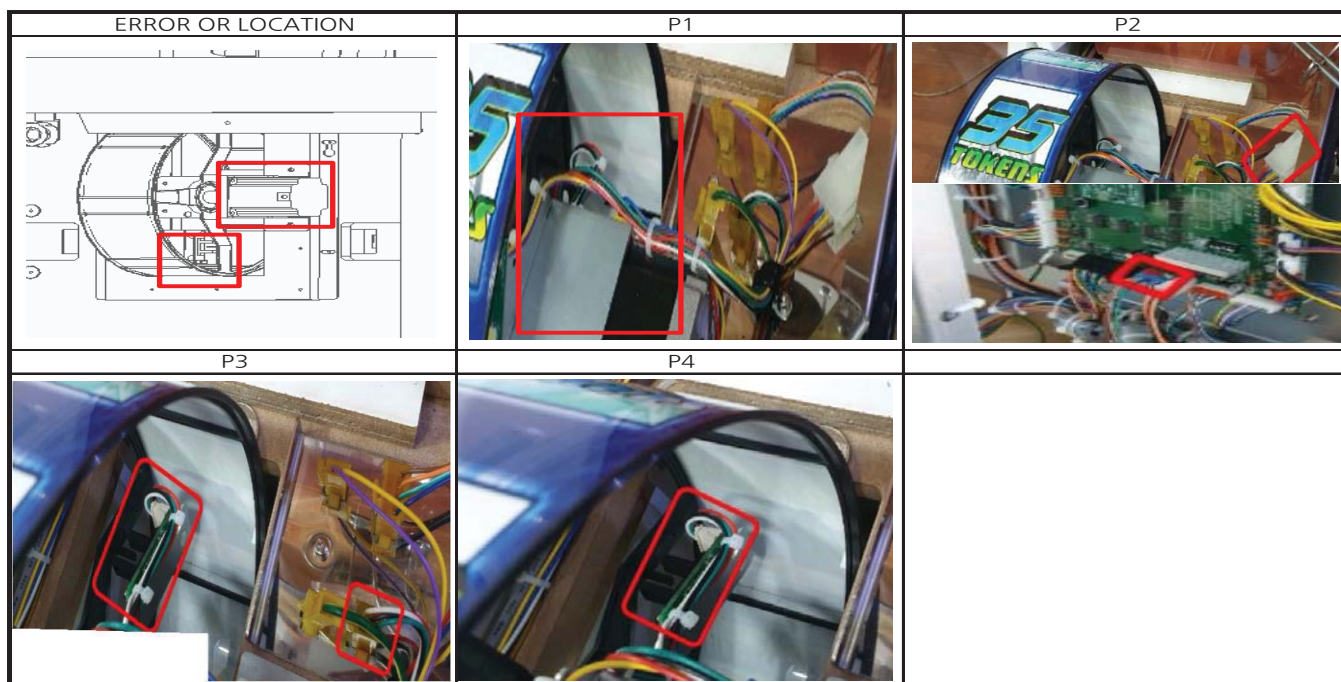

► SOLUTION : REEL MOTOR ERROR [E.31]

- 1 HOW TO TEST : TEST MODE → REEL TEST
- 2 Check connection of motor connector (P1)
- 3 Check assembly status of motor (P1)
- 4 Check connection of join connector and main pcb connector (P2)
- 5 Replace MOTOR
- 6 Replace MAIN PCB





PART NAME	CODE	PART NAME	CODE
STEPPING MOTOR NO WIRE	MZZZ0MOT167	MAIN PCB ASS'Y	AAV10PCB001

► SOLUTION : REEL SENSOR ERROR [E.31]

- 1 HOW TO TEST : TEST MODE → REEL TEST
Setup pcb- Select button -Shooting button-Sensor status check
(Detected Sensor : " _ " / Non-Detected sensor : " 0 ")
- 2 Check connection of sensor connector (P3)
- 3 Check assembly status of sensor , Check position of sensor bracket (Center) (P4)
- 4 Check the dc voltage (SENSOR PCB)
: PIN 1 : over 4.5V , PIN 2 : below 0.5V , PIN 4 : GND ,
PIN 3 : Detected Sensor over 4.5V / Non-detected sensor below 0.5V
- 5 Replace SENSOR PCB
- 6 Check the dc voltage (MAIN PCB / CN18) : PIN 5 : Over 4.5V , PIN 6 : Below 0.5V , PIN 8 : GND
- 7 Replace MAIN PCB

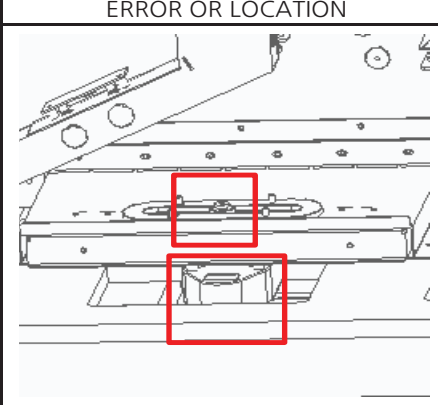
PART NAME	CODE	PART NAME	CODE
PHOTO INT-1 PCB ASS'Y	ACIR0PCB011	MAIN PCB ASS'Y	AAV10PCB001

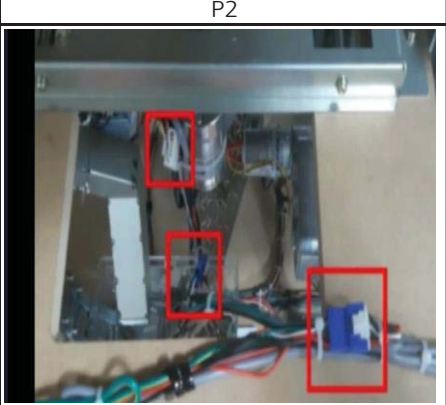
2) PUSHER MOTOR ERROR [E.41], PUSHER SENSOR ERROR [E.41]

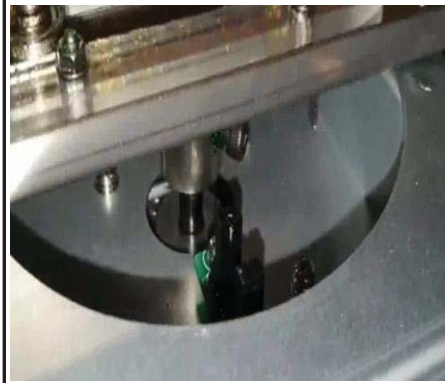
ERROR OR LOCATION	P1	P2
		
P3	P4	
		

► SOLUTION : PUSHER MOTOR ERROR [E.41]

- 1 HOW TO TEST TEST MODE → PUSHER MOTOR TEST → SELECT BUTTON → SHOOTING button
- 2 Check if tokens, cards, balls, side token are jamming the pusher plate (P1)
- 3 Check connection of motor connector , Check assembly status of motor (P2,P3)
- 4 Check the dc voltage (MAIN PCB / CN19)
 - : PIN 1 : Over 11V , PIN 3 : Below 0.5V , PIN 6 : GND ,
 - PIN 2 : Operation state over 4.5V / Non-operation state below 0.5V
- 5 Replace MOTOR
- 6 Replace MAIN PCB

PART NAME	CODE	PART NAME	CODE
MOTOR_BLDC	MZZZ0MOT152	MAIN PCB ASS'Y	AAV10PCB001

► SOLUTION -PUSHER SENSOR ERROR [E.41]

- 1 HOW TO TEST TEST MODE → PUSHER MOTOR TEST → SELECT BUTTON → SHOOTING button
- Sensor operation status : Detected Sensor : " _ " / Non-Detected sensor : " 0 "
- 1 Check if tokens, cards, balls, side token are jamming the pusher plate (P1)
 - 2 Check connection of sensor connector , Check assembly status of sensor (P4)
 - 3 Check the dc voltage (SENSOR PCB)
 - : PIN 1 : over 4.5V , PIN 2 : below 0.5V , PIN 4 : GND ,
 - PIN 3 : Detected Sensor over 4.5V / Non-detected sensor below 0.5V
 - 4 Replace SENSOR PCB
 - 5 Check the dc voltage (MAIN PCB / CN19) : PIN 7 : Over 4.5V , PIN 8 : Below 0.5V , PIN 10 : GND
 - 6 Replace MAIN PCB

PART NAME	CODE	PART NAME	CODE
PHOTO INT-1 PCB ASS'Y	AZZZ0PCB103	MAIN PCB ASS'Y	AAV10PCB001

3) TARGET WHEEL MOTOR & SENSOR ERROR [E.51]

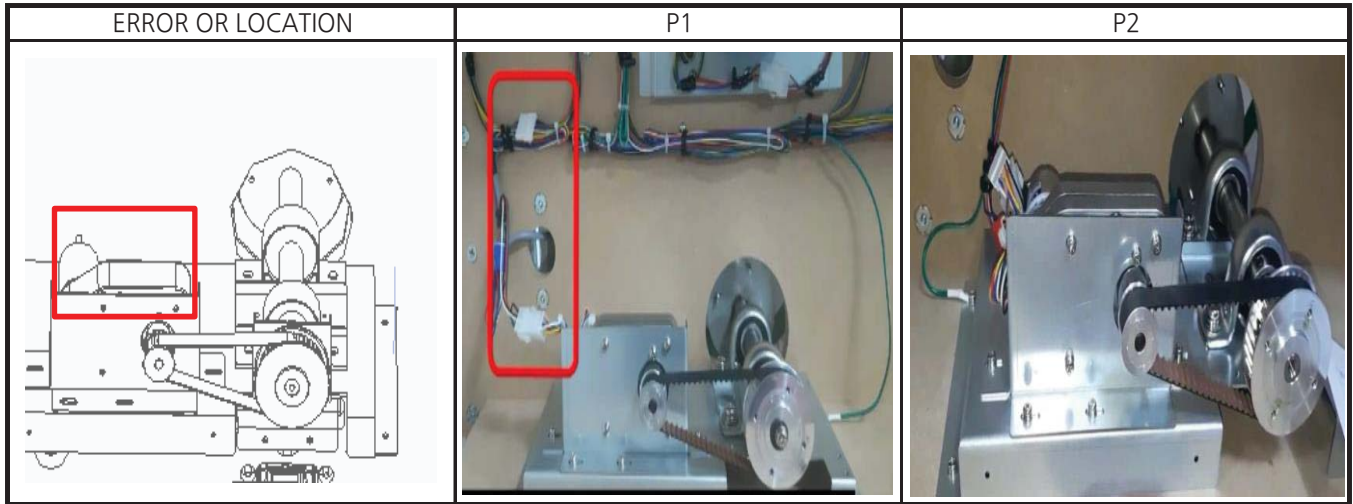

► SOLUTION

※ 1 HOW TO TEST MODE → WHEEL MOTOR TEST

SELECT button - SHOOTING button -Sensor operation status : First digit of the PLAY FND

Detected Sensor : " _ " / Non-Detected sensor : " 0 "

2 Check connection of motor connector (P1)

3 Check assembly status of belt and motor (P2)

4 Check the dc voltage (MAIN PCB / CN20)

: PIN 1 : Over 11V , PIN 3 : Below 0.5V , PIN 6 : GND ,

PIN 2 : Operation state over 4.5V / Non-operation state below 0.5V

5 Replace MOTOR (The sensor is in the motor,if the sensor is Not detected,replace the motor)

6 Replace MAIN PCB

PART NAME	CODE	PART NAME	CODE
MOTOR_BLDC	MZZZ0MOT160	MAIN PCB ASS'Y	AAV10PCB001

4) BIG WHEEL MOTOR ERROR [E.52],BIG WHEEL SENSOR ERROR [E.52]

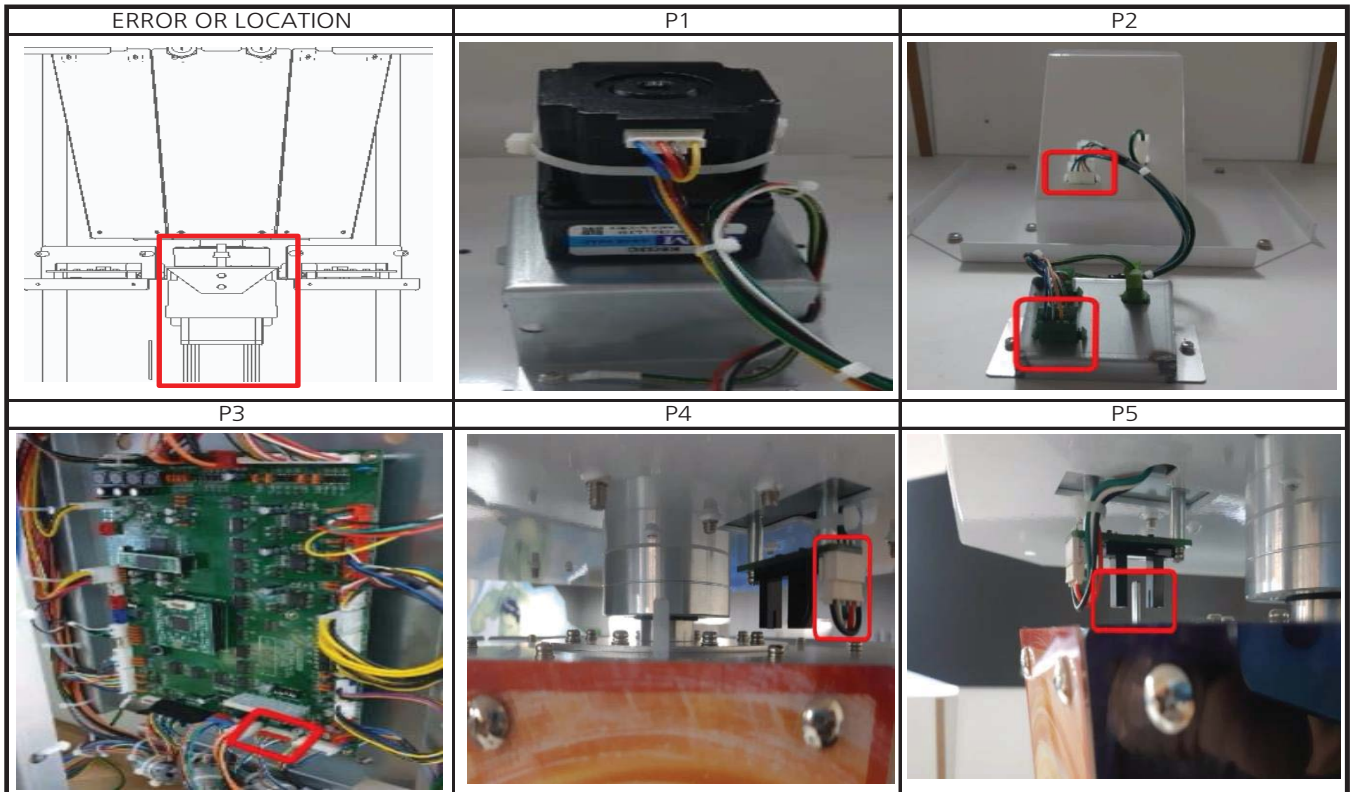

► SOLUTION : BIG WHEEL MOTOR ERROR [E.52]

- 1 HOW TO TEST : TEST MODE → BIG WHEEL TEST→ SELECT Button → SHOOTING button
- 2 Check connection of motor connector (p1)
- 3 Check assembly status of motor (P2)
- 4 Check connection of join connector and motor connector (CN17) (P2,P3)
- 5 Check DIP SWITCH setting status : 1,2,4,5,6 → OFF / 3 → ON
- 6 Replace MOTOR
- 7 Replace MAIN PCB

PART NAME	CODE	PART NAME	CODE
MOTOR_BLDC	MZZZ0MOT152	MAIN PCB ASS'Y	AAV10PCB001

► SOLUTION : BIG WHEEL SENSOR ERROR [E.52]

- ※ 1 HOW TO TEST MODE → BIG WHEEL TEST→ SELECT button →SHOOTING button
 Sensor operation status : Detected Sensor : flicker " _ " / Non-Detected sensor : " 0 "
- 2 Check connection of sensor connector (P4)
 - 3 Check assembly status of sensor , Check position of sensor bracket (Center) (P5)
 - 4 Check the dc voltage (SENSOR PCB)
 : PIN 1 : over 4.5V , PIN 2 : below 0.5V , PIN 4 : GND ,
 PIN 3 : Detected Sensor over 4.5V / Non-detected sensor below 0.5V
 - 5 Replace SENSOR PCB
 - 6 Check the dc voltage (MAIN PCB / CN17) : PIN 5 : Over 4.5V , PIN 6 : Below 0.5V , PIN 8 : GND
 - 7 Replace MAIN PCB

PART NAME	CODE	PART NAME	CODE
PHOTO INT-1 PCB ASS'Y	ACIR0PCB011	MAIN PCB ASS'Y	AAV10PCB001

5) FRONT HOPPER MOTOR ERROR [E.61], FRONT HOPPER SENSOR ERROR [E.61]

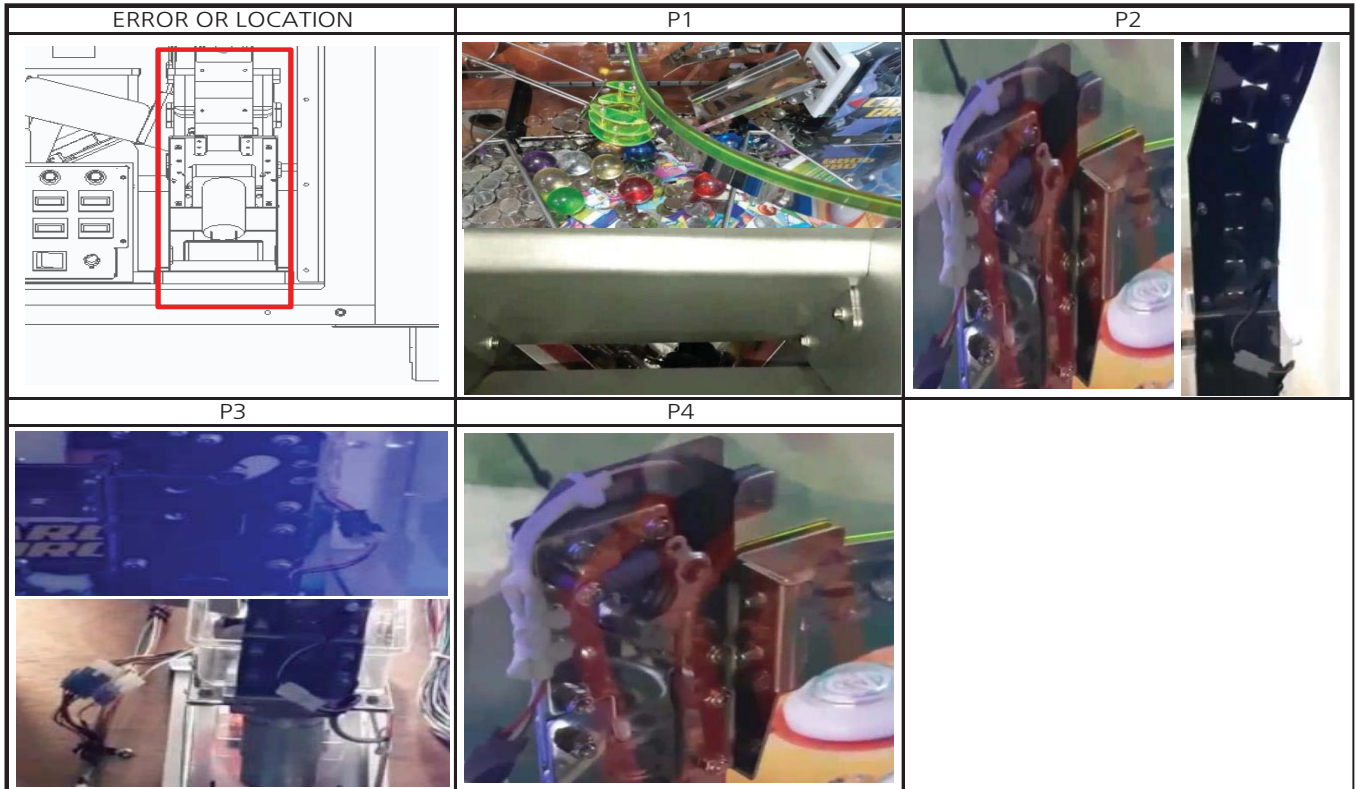

▶ SOLUTION : FRONT HOPPER MOTOR ERROR [E.61]

- ※ 1 HOW TO TEST : TEST MODE → FRONT HOPPER TEST → SELECT button → SHOOTING button
- 2 Check the jamming location Token Bridge, Pusher Plate and Conveyor (P1)
- 3 Foreign objects inside the HOPPER, Check jamming hopper disk, Check jamming hopper rail (P2)
- 4 Check the disk rotation direction, Check connection of motor connector (P3)
- 5 Check the operation of HOPPER PCB internal LED1 (lights up during operation), LED2 (flashes when 5V input), LED3 (flashes when 24V is input) (P4)
- 6 Check the dc voltage (HOPPER PCB / JP2) : PIN 1 : Over 23V , PIN 2 : GND
- 7 Replace HOPPER PCB
- 8 Check the dc voltage (MAIN PCB / CN10): A-PIN 1 : Over 23V , A-PIN 6 : Over 4.5V , A-PIN 10 : GND
- 9 Replace MAIN PCB

▶ SOLUTION : FRONT HOPPER SENSOR ERROR [E.61]

- 1 HOW TO TEST : TEST MODE → FRONT HOPPER TEST → SELECT button → SHOOTING button

※ CHECK LIST

- 1 Check the jamming location Token Bridge, Pusher Plate and Conveyor (P1)
- 2 Check the jamming launch part exit (P2)
- 3 Check the jamming hopper rail (P2)
- 4 Check connection of sensor connector (P3)
- 5 Check the foreign substances in the sensor part and the assembly status of the launch part (P4)
- 6 Check the dc voltage (SENSOR ASS'Y)
 - : PIN 1 : over 4.5V , PIN 3 : below 0.5V , PIN 4 : GND ,
 - PIN 2 : Detected Sensor over 4.5V / Non-detected sensor below 0.5V
- 7 Replace SENSOR PCB
- 8 Replace MAIN PCB

PART NAME	CODE	PART NAME	CODE
ELEVATOR SENSOR ASS'Y	AZZZ0PCB173	MAIN PCB ASS'Y	AAV10PCB001

6) REAR HOPPER MOTOR ERROR [E.62]

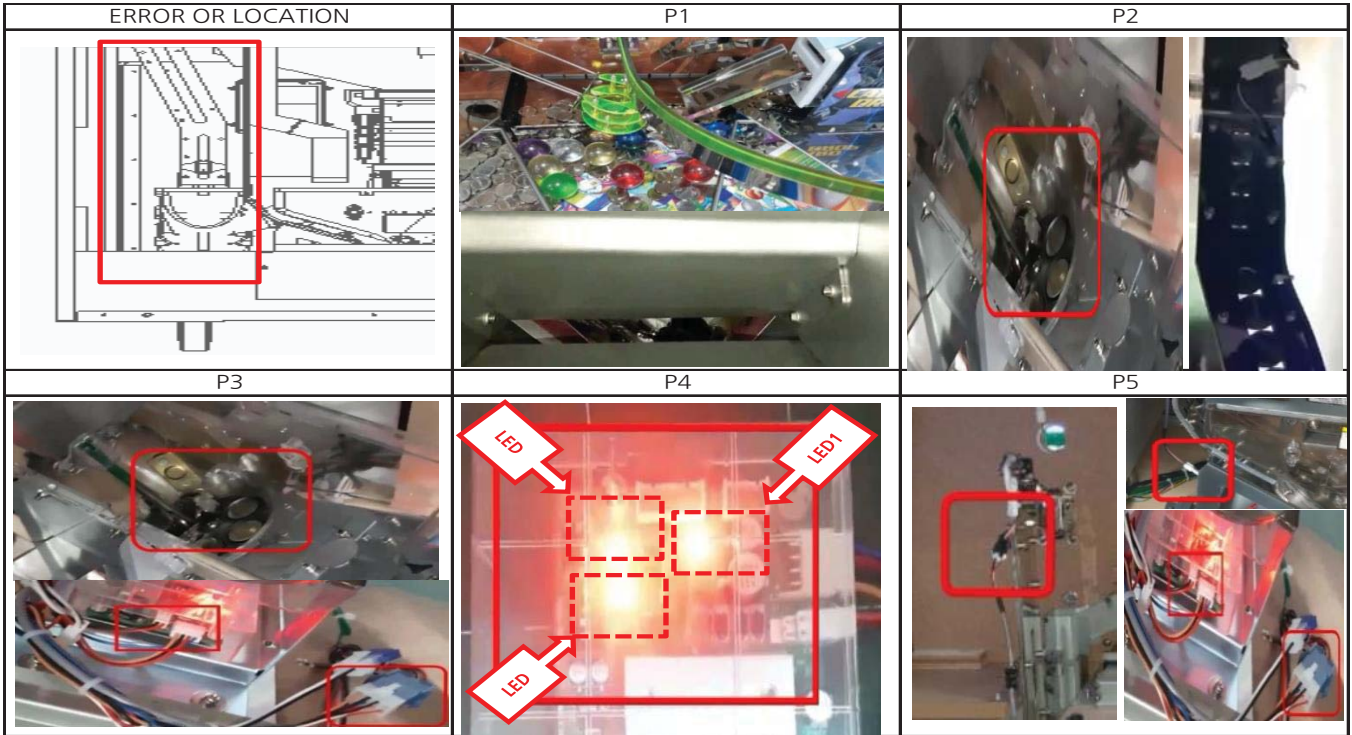

► SOLUTION : REAR HOPPER MOTOR ERROR [E.62]

- 1 HOW TO TEST TEST MODE → REAR HOPPER TEST→ SELECT button→SHOOTING button
- 2 Check the jamming location Token Bridge, Pusher Plate and Conveyor (P1)
- 3 Foreign objects inside the HOPPER,Check jamming hopper disk,Check jamming hopper rail (P 2)
- 4 Check the disk rotation direction, Check connection of motor connector (P)
- 5 Check the operation of HOPPER PCB internal LED1 (lights up during operation), LED2 (flashes when 5V input), LED3 (flashes when 24V is input) (P4)
- 5 Check the dc voltage (HOPPER PCB / JP2) : PIN 1 : Over 23V , PIN 2 : GND
- 6 Replace HOPPER PCB
- 7 Check the dc voltage (MAIN PCB / CN10) : B-PIN 1 : Over 23V , B-PIN 6 : Over 4.5V , B-PIN 10 : GND
- 8 Replace MAIN PCB

PART NAME	CODE	PART NAME	CODE
ELEVATOR HOPPER PCB ASS'Y	AZZZ0PCB143	MAIN PCB ASS'Y	AAV10PCB001

► SOLUTION : REAR HOPPER SENSOR ERROR [E.62]

- 1 HOW TO TEST TEST MODE → REAR HOPPER TEST→ SELECT button→SHOOTING button
PLAY FND 3rd digit confirms quantity change (reduced sequentially when sensor is detected)
- 2 Check the jamming location Token Bridge, Pusher Plate and Conveyor (P1)
- 3 Check the jamming launch part exit (P 2) Check the jamming hopper rail (P 2)
- 4 Check connection of sensor connector (P5)
- 5 Check the foreign substances in the sensor part and the assembly status of the launch part (P4)
- 6 Check the dc voltage (SENSOR ASS'Y) : PIN 1 : over 4.5V , PIN 3 : below 0.5V , PIN 4 : GND ,
PIN 2 : Detected Sensor over 4.5V / Non-detected sensor below 0.5V
- 7 Replace SENSOR PCB
- 8 Replace MAIN PCB

PART NAME	CODE	PART NAME	CODE
ELEVATOR SENSOR ASS'Y	AZZZ0PCB173	MAIN PCB ASS'Y	AAV10PCB001

7) BALL SUPPLY MOTOR ERROR [E.71], BALL SUPPLY SENSOR ERROR [E.71]

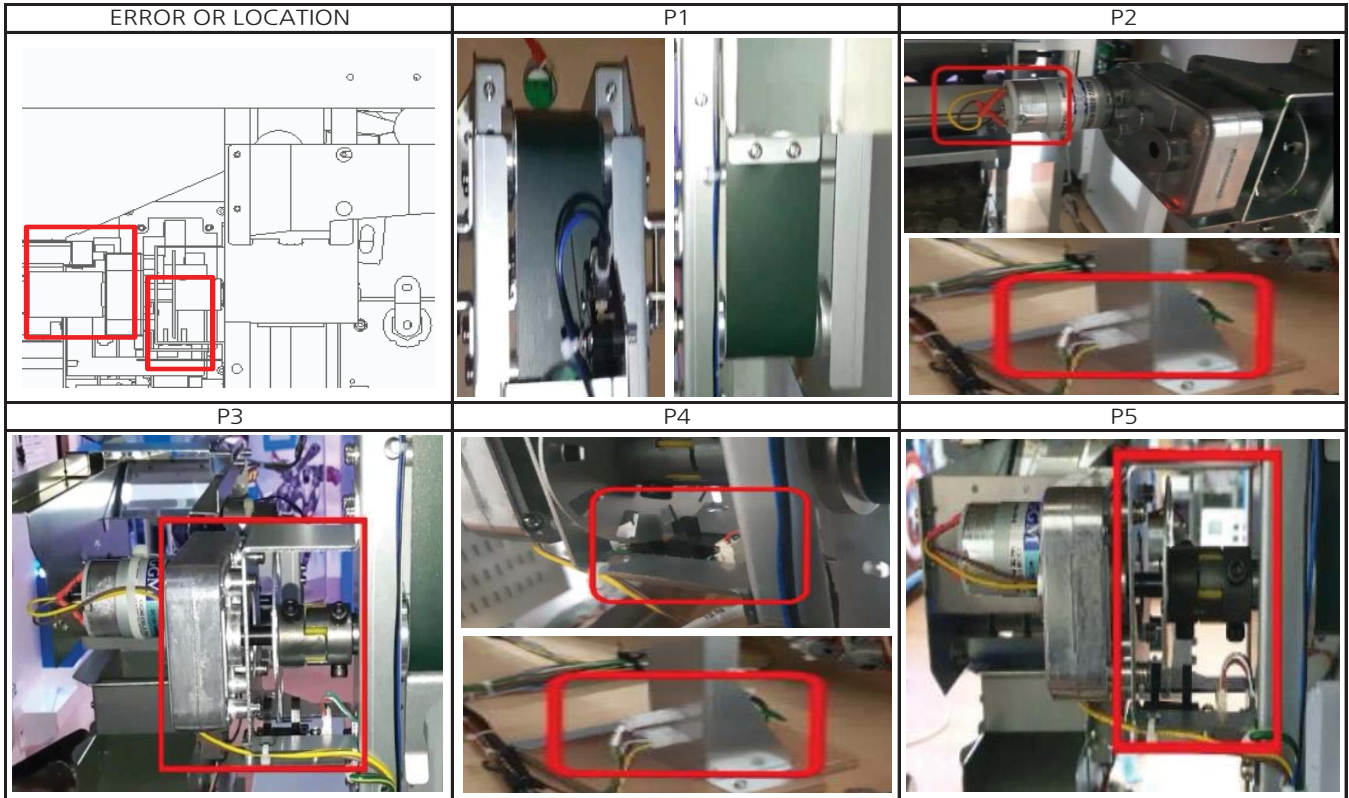

► SOLUTION : BALL SUPPLY MOTOR ERROR [E.71]

- 1 HOW TO TEST : TEST MODE → BALL SUPPLY TEST → SELECT button → SHOOTING button
- 2 Check the jamming ball supply rail , Check for BKT jams during belt drive (P1)
- 3 Check connection of motor connector (P2)
- 4 Check assembly status of motor (P3)
- 5 Check the dc voltage (MAIN PCB / CN16) : PIN 1 : Over 11V , PIN 2 : GND
- 6 Replace MOTOR
- 7 Replace MAIN PCB

PART NAME	CODE	PART NAME	CODE
MOTOR	MZZZ0MOT161	MAIN PCB ASS'Y	AAV10PCB001

► SOLUTION : BALL SUPPLY SENSOR ERROR [E.71]

- 1 HOW TO TEST : TEST MODE → BALL SUPPLY TEST → SELECT button → SHOOTING button
: Third digit of the PLAY FND - Detected Sensor : flicker " _ " / Non-Detected sensor : " 0 "
- 2 Check connection of sensor connector (P4)
- 3 Check assembly status of sensor , Check position of sensor bracket (Center) (P5)
- 4 Check the dc voltage (SENSOR PCB) : PIN 1 : over 4.5V , PIN 2 : below 0.5V , PIN 4 : GND ,
PIN 3 : Detected Sensor over 4.5V / Non-detected sensor below 0.4V
- 5 Replace SENSOR PCB
- 6 Check the dc voltage (MAIN PCB / CN16) : PIN 3 : Over 4.5V , PIN 4 : Below 0.5V , PIN 6 : GND
- 7 Replace MAIN PCB

PART NAME	CODE	PART NAME	CODE
PHOTO INT-1 PCB ASS'Y	ACIR0PCB011	MAIN PCB ASS'Y	AAV10PCB001

8) BALL SUPPLY SWITCH ERROR [E.72]

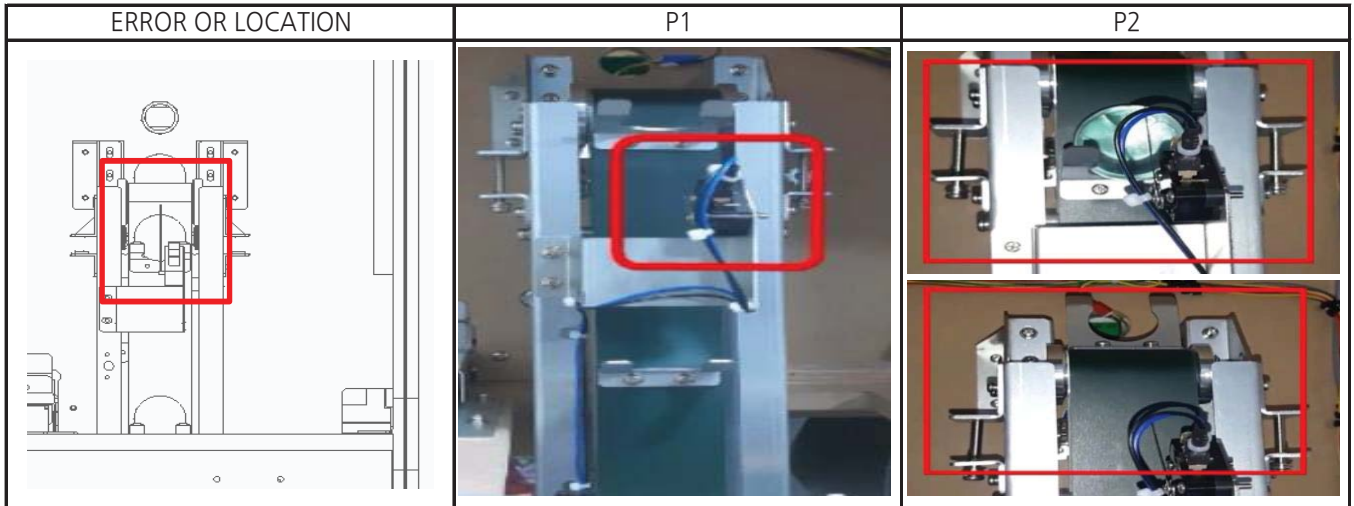

► SOLUTION

- 1 HOW TO TEST :TEST MODE → BALL SUPPLY TEST →SELECT button→ SHOOTING button
:Sensor operation status : Detected Sensor : " 0 " / Non-Detected sensor : " _ "
- 2 Check connection of switch connector and pin connector (P1), SWITCH external status check (P1)
- 3 When SWITCH is recognized, it checks whether it was pressed normally, and returns to its original state if not recognized. (P 2)
- 4 Check the dc voltage (SWITCH)
: NO PIN : over 4.5V (ball is not mounting) / Below 0.5V (ball is mounting) , COM PIN : GND
- 5 Replace SWITCH PCB
- 6 Check the dc voltage (MAIN PCB / CN16)
: PIN 7 : over 4.5V (ball is not mounting) / Below 0.5V (ball is mounting) , PIN 8 : GND
- 7 Replace MAIN PCB

PART NAME	CODE	PART NAME	CODE
MICRO SWITCH	MELEOMIC002	MAIN PCB ASS'Y	AAV10PCB001

9) BALL IN SENSOR ERROR [E.73]

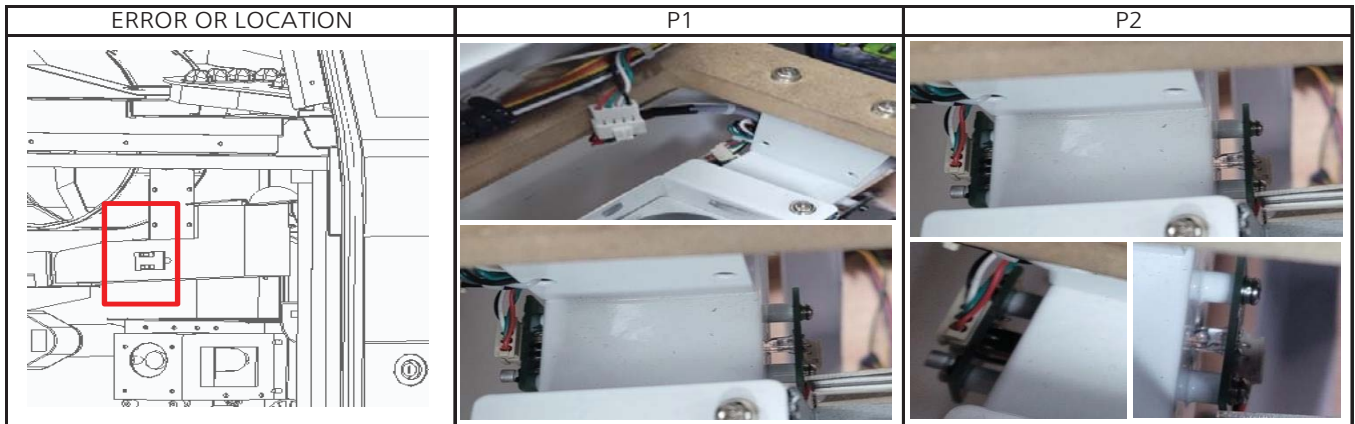

► SOLUTION

1 HOW TO TEST :TEST MODE → BALL IN TEST

Insert the ball into the inlet and check the sensor operation status at the 4th digit of TICKET FND
(Increases sequentially according to the number of inputs)

Detected sensor : increase in number , non-detected sensor : No change in number

2 Check connection of sensor connector (CHECK 1)

3 Check assembly status of sensor (CHECK 2)

4 Check the dc voltage (SENSOR PCB) : PIN 1 : over 4.5V , PIN 2 : below 0.5V , PIN 4 : GND ,
PIN 3 : Detected Sensor over 4.5V / Non-detected sensor below 0.5V

5 Replace SENSOR PCB

6 Check the dc voltage (MAIN PCB / CN16) : PIN 9 : over 4.5V , PIN 10 : Below 0.5V , PIN 12 : GND

7 Replace MAIN PCB

PART NAME	CODE	PART NAME	CODE
SENSOR_R PCB ASS'Y	MEIF0PAR014	SENSOR_T PCB ASS'Y	AAV20PCB011
MAIN PCB ASS'Y	AAV10PCB002		

10) TOKEN BRIDGE MOTOR ERROR [E.81 & 82]

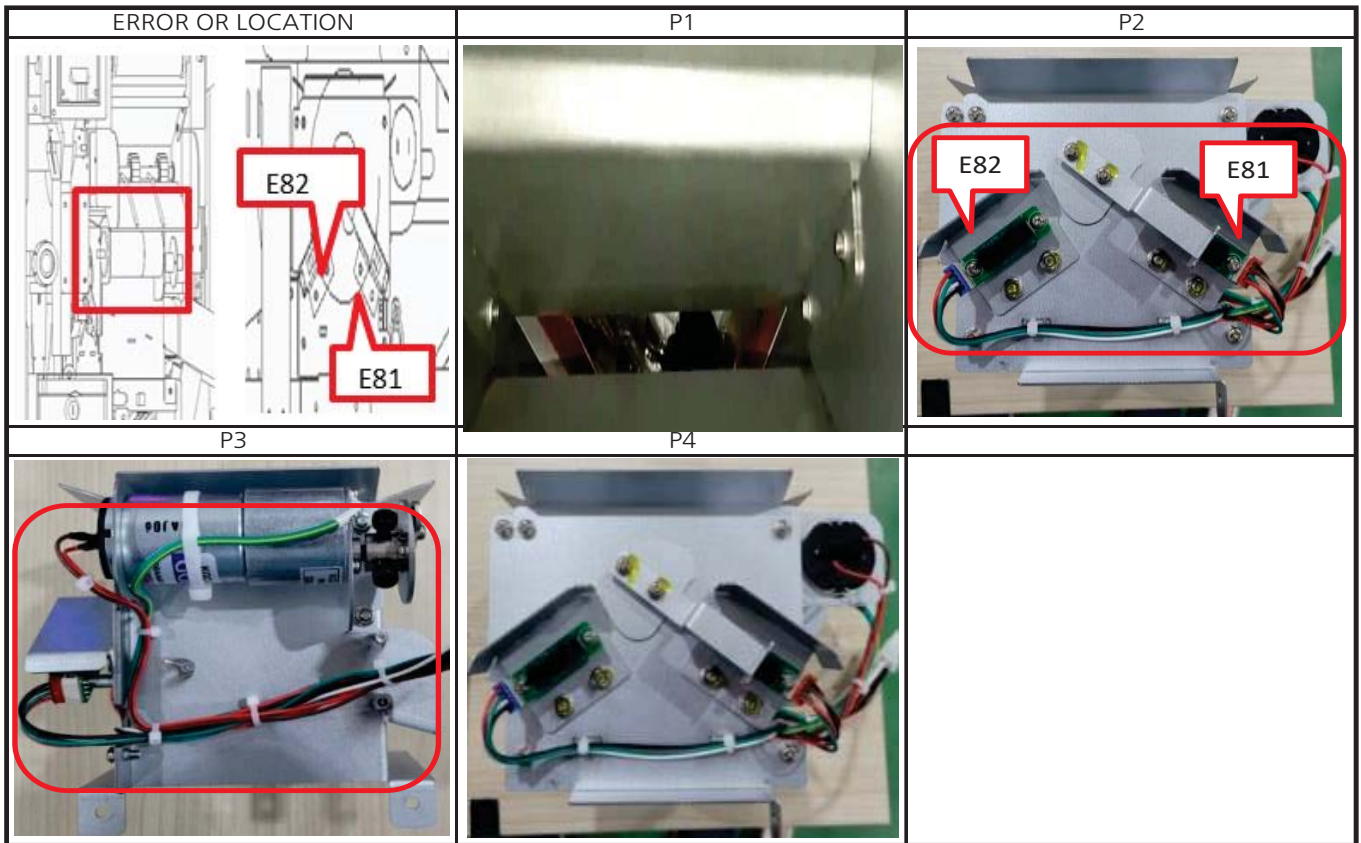

► SOLUTION : TOKEN BRIDGE MOTOR ERROR [E.81 & 82]

- 1 HOW TO TEST TEST MODE → TOKEN BRIDGE TEST → SELECT button → SHOOTING button
- 2 Check internal JAM by foreign material, card, token (P1)
- 3 Check MOTOR connector connection status (P2)
- 4 Check assembly status (P3)
- 5 voltage check (MAIN PCB / CN16) : PIN 1 : 11V , PIN 2 : GND
- 6 MOTOR replacement 7 MAIN PCB replacement

PART NAME	CODE	PART NAME	CODE
MOTOR	MZZZ0MOT173	MAIN PCB ASS'Y	AAV10PCB001

► SOLUTION : TOKEN BRIDGE FRONT SENSOR ERROR [E.81]

- 1 HOW TO TEST : TEST MODE → TOKEN BRIDGE TEST
sensor status check-Detected Sensor : " _ " / Non-Detected sensor : " 0 "
- 2 Check internal JAM by foreign material, card, token (P1)
- 3 SENSOR PCB wiring connection and connector connection status check (P2)
- 4 Check the sensor assembly status (P4)
- 5 voltage check (SENSOR PCB) : PIN 1 : 4.5V, PIN 2 : 0.5V, PIN 4 : GND ,
PIN 3 : 4.5V or more when detected / Less than 0.5V when not detected
- 5 SENSOR PCB replacement 6 voltage check (MAIN PCB / CN15)
: PIN 3: 4.5V or higher, PIN 4: less than 0.5V, PIN 7: GND
- 7 MAIN PCB replacement

PART NAME	CODE	PART NAME	CODE
PHOTO INT-1 PCB ASS'Y	ACIR0PCB011	MAIN PCB ASS'Y	AAV10PCB001

► SOLUTION : TOKEN BRIDGE REAR SENSOR ERROR [E.82]

1 HOW TO TEST : TEST MODE → TOKEN BRIDGE TEST

PLAY FND First digit sensor operation status check-Detected Sensor : " _ " / Non-Detected sensor : " 0 "

2 Check internal JAM by foreign material, card, token (P1)

3 SENSOR PCB wiring connection and connector connection status check (P2)

4 Check the sensor assembly status (P3)

5 voltage check (SENSOR PCB) : PIN 1: more than 4.5V, PIN 2: less than 0.5V, PIN 4: GND ,
PIN 3: more than 4.5V when detected / less than 0.5V when not detected

4 SENSOR PCB replacement

5 voltage check (MAIN PCB / CN15) : PIN 3: 4.5V or higher, PIN 4: less than 0.5V, PIN 7: GND

6 MAIN PCB replacement

PART NAME	CODE	PART NAME	CODE
PHOTO INT-1 PCB ASS'Y	ACIR0PCB011	MAIN PCB ASS'Y	AAV10PCB001

11) CONVEYER MOTOR ERROR [E.91],CONVEYER SENSOR ERROR [E.91]

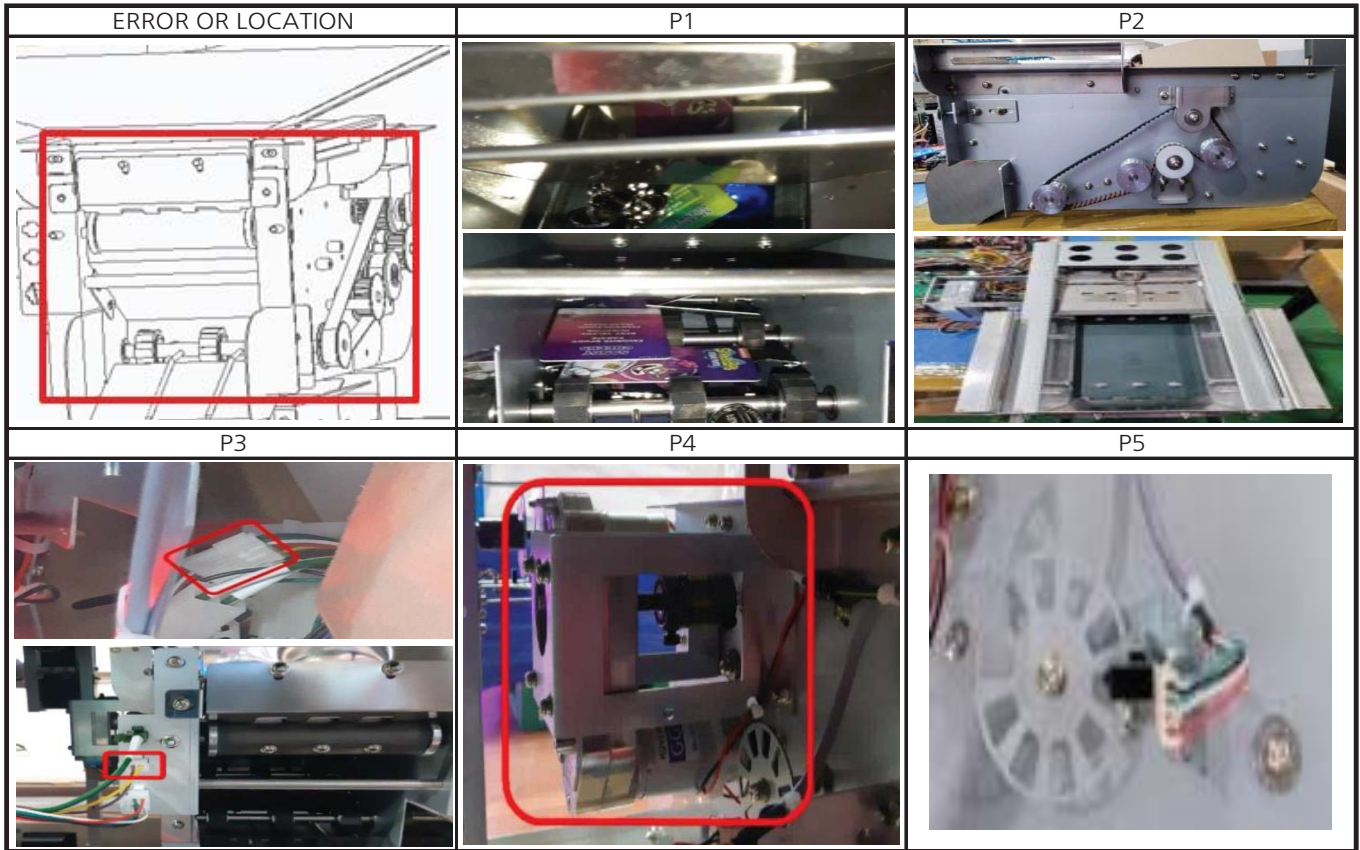

► SOLUTION : CONVEYER MOTOR ERROR [E.91]

- 1 HOW TO TEST TEST MODE → CONVEYER TEST → SELECT button → SHOOTING button
- 2 Check internal JAM by TOKEN , CARD , BALL (P 1)
- 3 TIMING BELT , MAIN BELT Check for abnormalities (P 2)
- 4 Check MOTOR connector connection status (P 3)
- 5 Check the assembly status of the equipment and check whether the parts are deformed (P 4)
- 6 voltage check (MAIN PCB / CN5) : PIN 1: 11V or higher, PIN 2: GND
- 7 MOTOR replacement
- 8 MAIN PCB replacement

PART NAME	CODE	PART NAME	CODE
MOTOR	MZZZ0MOT168	MAIN PCB ASS'Y	AAV10PCB001

► SOLUTION : CONVEYER SENSOR ERROR [E.91]

- 1 HOW TO TEST TEST MODE → CONVEYER TEST
- 2 Check the sensor status in the first digit of PLAY FND:When detected: " _ " / When not detected: " 0 "
- 3 Check internal JAM by TOKEN , CARD , BALL (P 1)
- 4 SENSOR PCB wiring connection and connector connection status check (P3)
- 5 Check the sensor assembly status, check the sensor check bracket position (center) (P 5)
- 6 voltage check (SENSOR PCB) : PIN 1: more than 4.5V, PIN 2: less than 0.5V, PIN 4: GND ,
PIN 3: more than 4.5V when detected / less than 0.5V when not detected
- 7 SENSOR PCB replacement
- 8 voltage check (MAIN PCB / CN5) : PIN 3 : above 4.5V, PIN 4 : below 0.5V, PIN 6 : GND
- 9 MAIN PCB replacement

PART NAME	CODE	PART NAME	CODE
PHOTO INT-1 PCB ASS'Y	AZZZ0PCB103	MAIN PCB ASS'Y	AAV10PCB001

12) CARD DISPENSER MOTOR ERROR [E.c1],CARD DISPENSER SENSOR ERROR [E.c1]

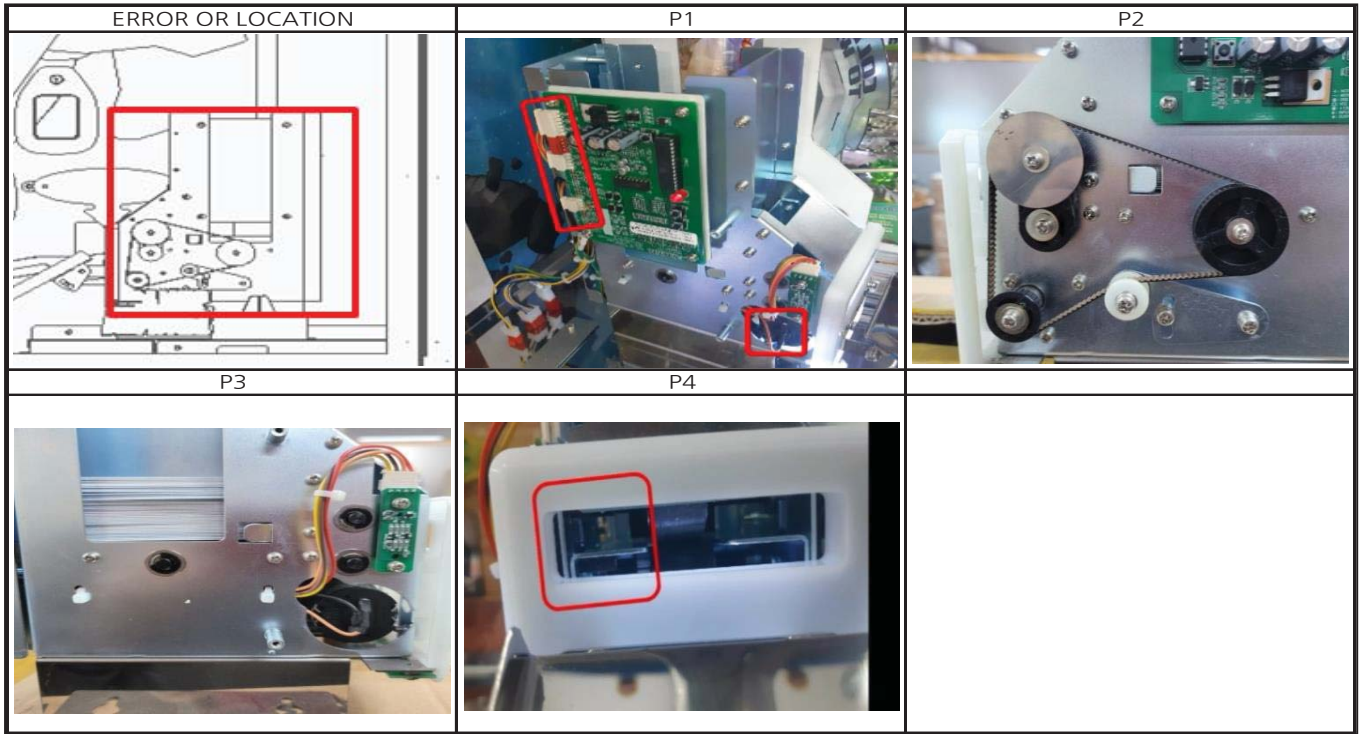

► SOLUTION : CARD DISPENSER MOTOR ERROR [E.c1]

- 1 HOW TO TEST TEST MODE → CARD DISPEN TEST → SELECT button →SHOOTING button
- 2 Check MOTOR connector connection status (P1)
- 3 Check assembly status (P2)
- 4 Check operation status (P 2)
- 5 voltage check (CARD DISPENSER PCB / CN7) : PIN 5 : 11V 이상 , PIN 2 : GND
- 6 voltage check (CARD DISPENSER PCB / CN1) : PIN 1 : GND , PIN 3 : 11V 이상
- 7 MOTOR replacement
- 8 voltage check (MAIN PCB / CN21) : PIN 1/2 : 11V or higher, PIN 5/6 : GND
- 9 MAIN PCB replacement

PART NAME	CODE	PART NAME	CODE
MOTOR	MZZZ0MOT089	MAIN PCB ASS'Y	AAV10PCB001

► SOLUTION : CARD DISPENSER SENSOR ERROR [E.c1]

- 1 HOW TO TEST TEST MODE → CARD DISPEN TEST → SELECT button →SHOOTING button
When detected: " _ " / When not detected: " 0 "
- 2 SENSOR PCB wiring connection and connector connection status check (P1)
- 3 Check the sensor assembly status and check the sensor bracket hole and sensor position(P3,P4)
- 4 voltage check (SENSOR PCB) : PIN 3: 4.5V or more, PIN 4: less than 0.5V, PIN 2: GND ,
PIN 1: 4.5V or more when detected / less than 0.5V when not detected
- 5 SENSOR REPLACEMENT
- 6 voltage check(CARD DISPENSER PCB/CN5): PIN 1: more than 4.5V, PIN 2: less than 0.5V, PIN 3: GND
- 7 CARD DISPENSER PCB replacement
- 8 voltage check (MAIN PCB / CN21) : PIN 1/2 : 11V or higher, PIN 5/6 : GND
- 9 MAIN PCB replacement

PART NAME	CODE	PART NAME	CODE
PHOTO INT-1 PCB ASS'Y	AZZZ0PCB103	MAIN PCB ASS'Y	AAV10PCB001

13) TOKEN SUCCESS SENSOR ERROR

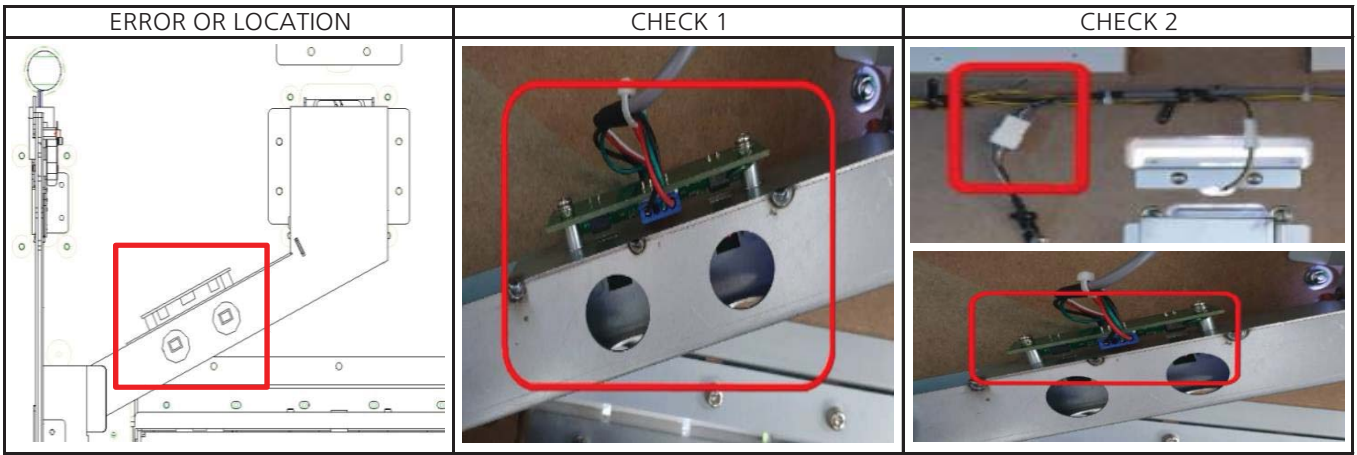

► SOLUTION

※ 1 HOW TO TEST TEST MODE → INPUT TEST

Check the sensor operation status - detected: " _ " / When not detected: " 0 "

- 2 Check if sunlight penetrates into the sensor area (CHECK 1)
- 3 SENSOR PCB wiring connection and connector connection status check (CHECK 2)
- 4 Check the sensor assembly status, check the presence of foreign substances inside (CHECK 1)
- 5 voltage check (SENSOR PCB) : PIN 1: 4.5V or more, PIN 4: GND ,
PIN 2: less than 0.5V when detected / more than 4.5V when not detected
- 6 SENSOR PCB replacement
- 7 voltage check (MAIN PCB / CN5) : PIN 1: above 4.5V, PIN 8: GND
- 8 MAIN PCB replacement

PART NAME	CODE	PART NAME	CODE
CHUTE SENSOR PCB ASS'Y	ASAW0PCB001	MAIN PCB ASS'Y	AAV10PCB001

8 EXPLODED VIEW

► FULL DESCRIPTION

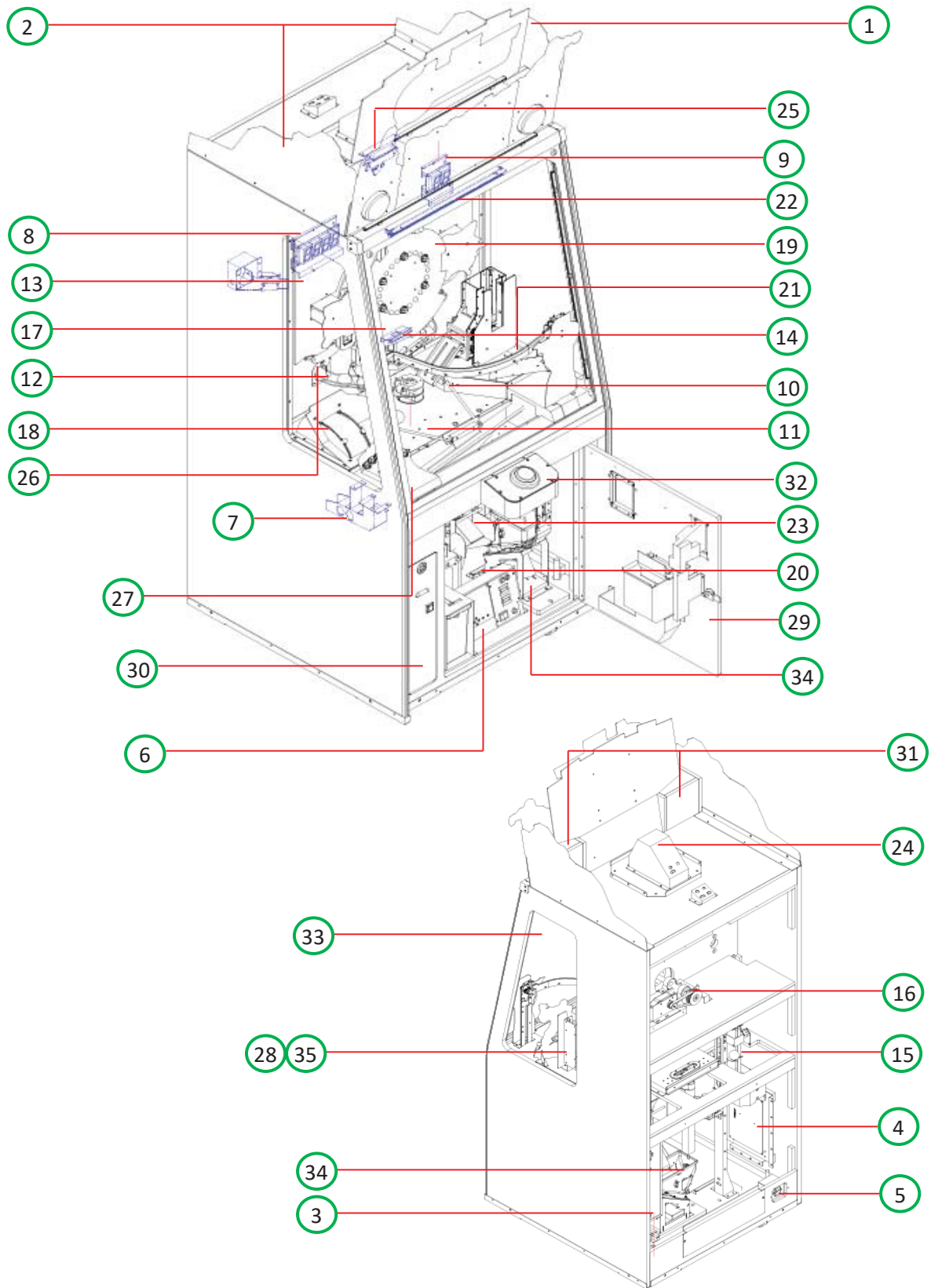

NO	PART NAME	SPEC	Q'TY	PAGE
1	BILLBOARD PART	-	1	p44
2	BILLBOARD CABINET SIDE DECO ACRYL - L, R PART	-	2	p44
3	SMPS PART	-	1	p45
4	MAIN BOARD PART	-	1	p45
5	AC INPUT PART	-	1	p45
6	MAIN BOARD PART	-	1	p46
7	BIG BALL OUTLET SENSOR PART	-	1	p46
8	TICKET FND PCB PART	-	1	p46
9	CREDIT FND PCB PART	-	1	p46
10	SIDE PAYOUT GUIDE L, R PART	-	2	p47
11	MOVING PUSHER PART	-	1	p47
12	BIG BALL INLET GUIDE RAIL PART	-	1	p48
13	WHEEL COIN INLET RAIL PART	-	1	p48
14	TARGET WHEEL LIGHTING PCB PART	-	1	p48
15	BIG BALL ELEVATOR PART	-	1	p49
16	BIG BALL INLET GUIDE RAIL PART	-	1	p50
17	TARGET WHEEL PART	-	1	p50
18	SLOT WHEEL PART	-	1	p51
19	TARGET WHEEL DECO COVER PART	-	1	p51
20	TOKEN BRIDGE PART	-	1	p52
21	COIN SHOOTING RAIL PART	-	1	p52
22	TOP LED LAMP PART	-	1	p52
23	MEDAL ROLLER PART	-	1	p53
24	BIG WHEEL PART	-	1	p54
25	BIG WHEEL WIN LED PART	-	1	p55
26	BONUS WIN OUTLET COVER ACRYL PART	-	2	p55
27	GAUNTLET DECO PART	-	1	p55
28	CARD DISPENSER PART	-	1	p56
29	FRONT DOOR PART	-	1	p57
30	TICKET DOOR PART	-	1	p57
31	SPEAKER BOX - L, R PART	-	2	p57
32	BUTTON PANEL PART	-	1	p58
33	FRONT DOOR GLASS PART	-	1	p58
34	FRONT, REAR ELEVATOR HOPPER PART	-	2	p58
35	THANOS DECO PART	-	1	p58

► DETAILED EXPLANATION

1) BILLBOARD PART

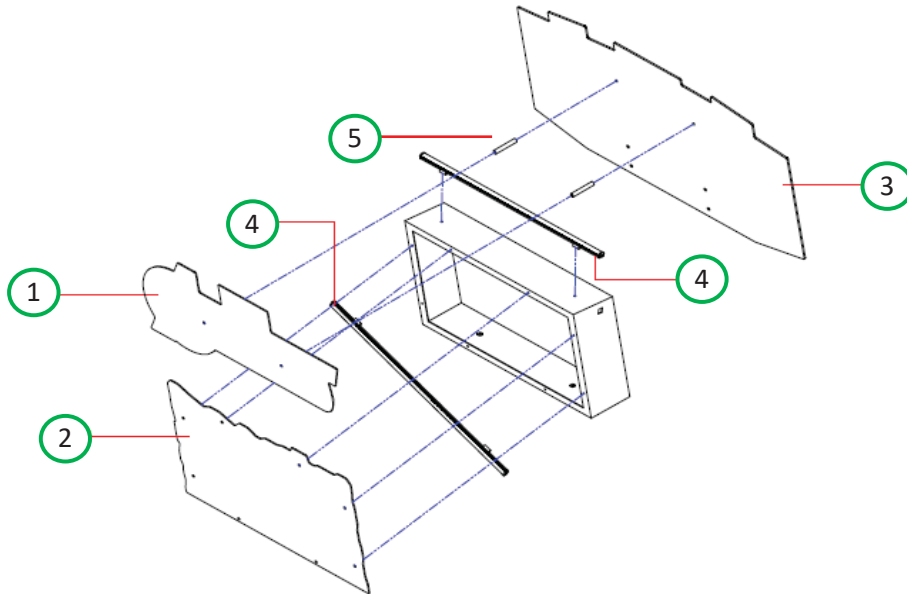

NO	PART NAME	SPEC	Q'TY	CODE NO
1	BILLBOARD DECO MAIN COVER-B	PET 2T	1	AAV10ACP002
2	BILLBOARD MAIN FRONT COVER	PET 2T	1	AAV10ACP015
3	BILLBOARD DECO MAIN COVER-A	FORMAX 3T	1	AAV10ACP001
4	LED BAR PCB ASS'Y	460 MM	2	AZZZ0PCB124
5	BILLBOARD SUPT BAR-A	-	2	MAV20PRO008

2) BILLBOARD CABINET SIDE DECO ACRYL - L, R PART

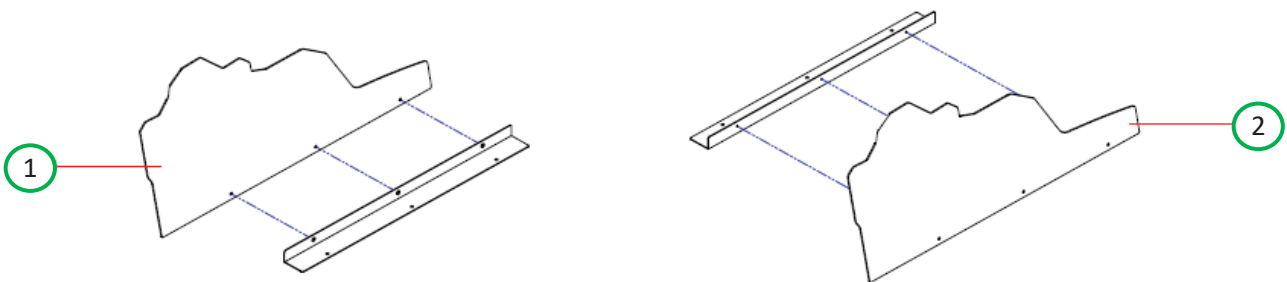

NO	PART NAME	SPEC	Q'TY	CODE NO
1	BILLBOARD CABINET SIDE DECO ACRYL-L	PET 2T	1	AAV10ACP003
2	BILLBOARD CABINET SIDE DECO ACRYL-R	PET 2T	1	AAV10ACP004

3) SMPS PART

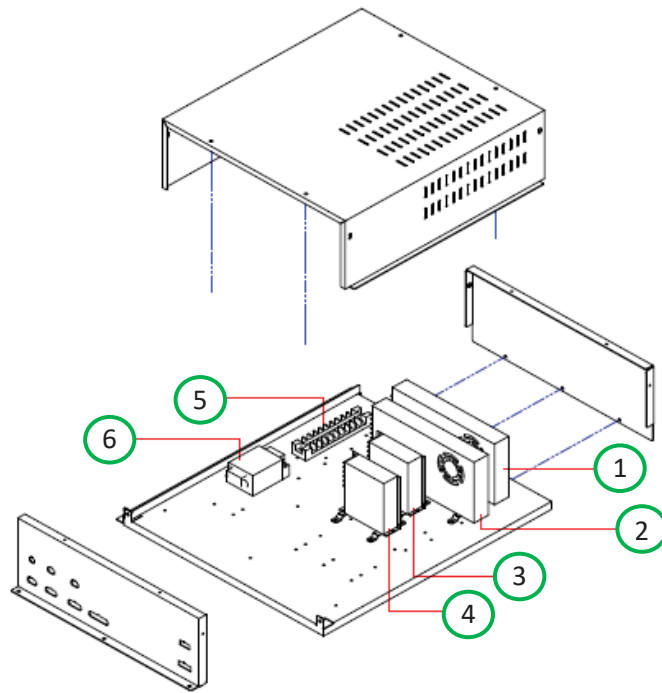

NO	PART NAME	SPEC	Q'TY	CODE NO
1	POWER SMPS	RSP-320-12	1	MELE0SMP109
2	POWER SMPS	RSP-320-24	1	MELE0SMP100
3	POWER SMPS	LRS 75-12	1	MELE0SMP093
4	POWER SMPS	LRS75-5	1	MELE0SMP094
5	TERMINAL BLOCK	250V 10P UL_CE	1	MELE0TEB003
6	NOISE FILTER	RNS-2010	1	MELE0NOI009

4) MAIN BOARD PART

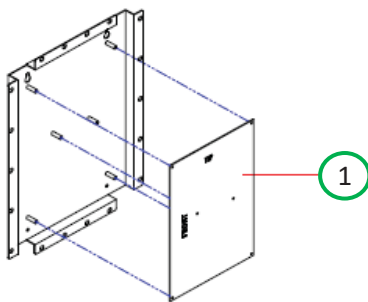

5) AC INPUT PART

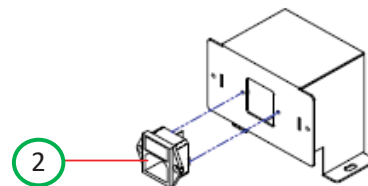

NO	PART NAME	SPEC	Q'TY	CODE NO
1	MAIN BOARD PCB ASS'Y	-	1	AAV10PCB001
2	AC INPUT	DAC-13H	1	AELE0FUS002

6) MAIN BOARD PART

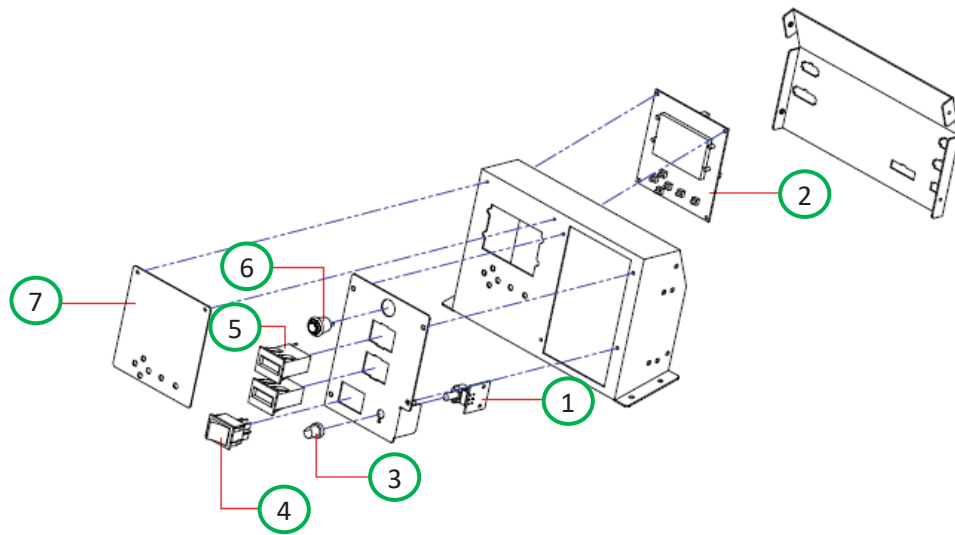

NO	PART NAME	SPEC	Q'TY	CODE NO
1	VOLUME PCB ASS'Y	-	1	AHM20PCB016
2	SETUP LCD PCB ASS'Y	-	1	AZZZ0PCB113
3	VOLUME KNOB	-	1	MELE0VOL007
4	ROCKER SWITCH	R595KDF	1	MELE0SWI021
5	COUNTER	AMMC-712(OA127CL)	2	MZZZ0COU002
6	PUSH BUTTON SWITCH	DS-412R	2	MELE0PUS006
7	SETUP PANEL BKT PET COVER	-	1	MSBP0ACR040

7) BIG BALL OUTLET SENSOR PART

8) TICKET FND PCB PART

9) CREDIT FND PCB PART

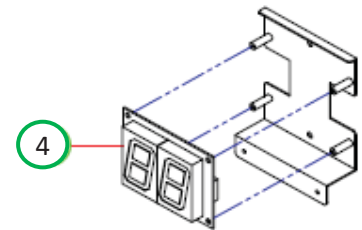
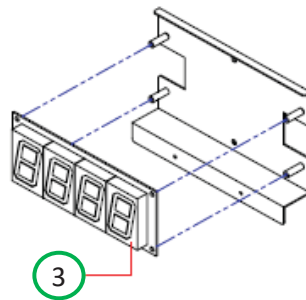
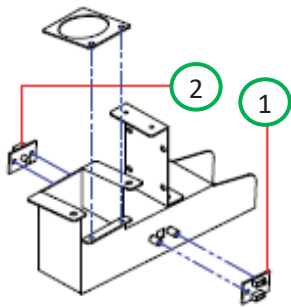

NO	PART NAME	SPEC	Q'TY	CODE NO
1	SENSOR_R PCB ASS'Y	-	1	MEIF0PAR014
2	SENSOR_T PCB ASS'Y	-	1	AAV20PCB011
3	FND PCB ASS'Y	3856-4(STRAIGHT)	1	AFND0PCB007
4	FND PCB ASS'Y	3856-2(STRAIGHT)	1	AFND0PCB006

10) SIDE PAYOUT GUIDE L, R PART



NO	PART NAME	SPEC	Q'TY	CODE NO
1	SIDE PAYOUT GUIDE MOLD	-	2	MDCC0PLA010

11) MOVING PUSHER PART

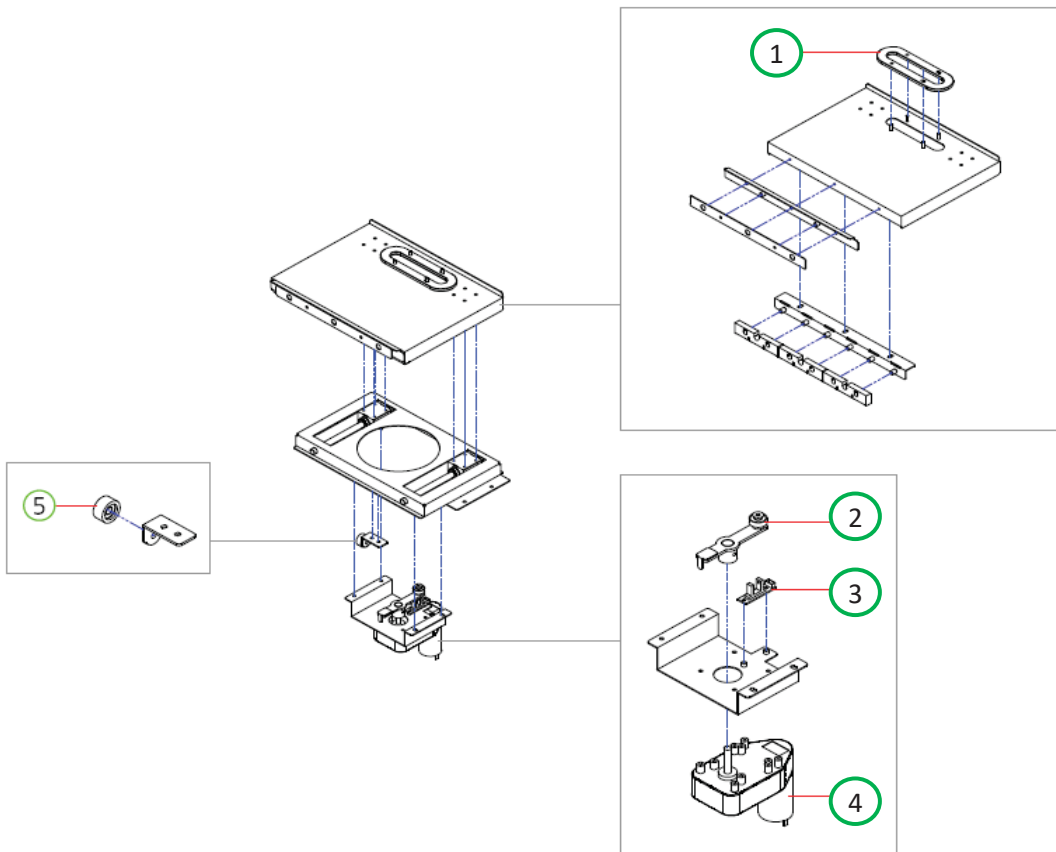

NO	PART NAME	SPEC	Q'TY	CODE NO
1	MOVING PUSHER ROTATE GUIDE	ACRYL-5T	1	MAV20ACR010
2	BEARING	626ZZ	1	MZZZ0BEA087
3	PHOTO-INT1(ANGLE) PCB ASS'Y	ANGLE TYPE	1	AZZZ0PCB103
4	MOTOR	KGV-2-0350-KB3640S1	1	MZZZ0MOT152
5	PUSHER BEARING	696ZZ	1	MSBP0PRO002

12) BIG BALL INLET GUIDE RAIL PART

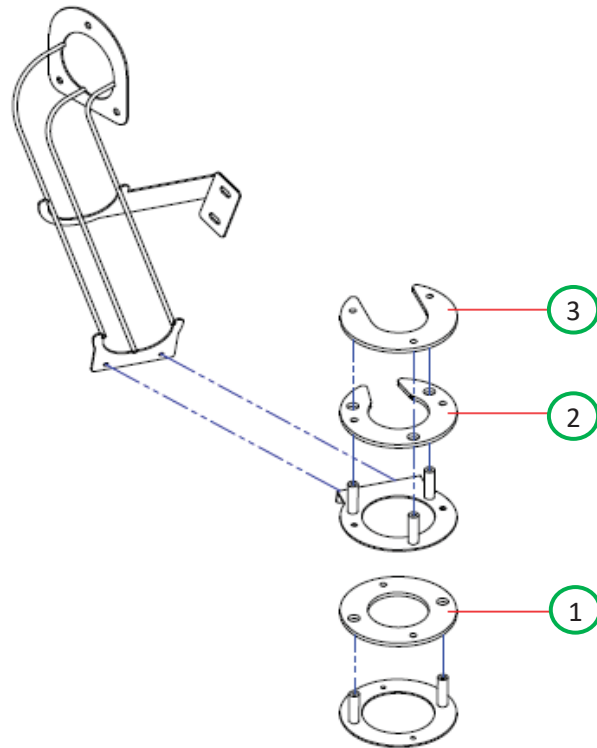

NO	PART NAME	SPEC	Q'TY	CODE NO
1	BIG BALL INLET GUIDE RAIL ACRYL-C	PC 3T	1	MAV20ACR043
2	BIG BALL INLET GUIDE RAIL ACRYL-B	PC 3T	1	MAV20ACR042
3	BIG BALL INLET GUIDE RAIL ACRYL-A	PC 3T	1	MAV20ACR043

13) WHEEL COIN INLET RAIL PART

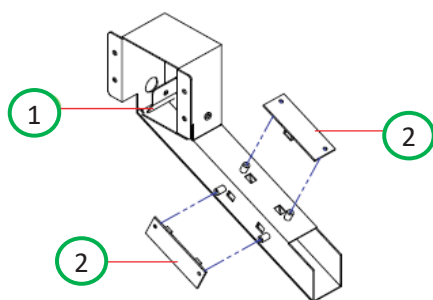

14) TARGET WHEEL LIGHTING PCB PART

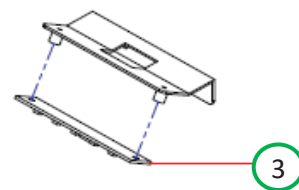

NO	PART NAME	SPEC	Q'TY	CODE NO
1	WHEEL COIN INLET RAIL ACRYL	PC 1T	1	MAV20ACR007
2	CHUTE SENSOR PCB ASS'Y	IR SENSOR	2	ASAW0PCB001
3	LED PCB ASS'Y	ANGLE TYPE	1	AMUM0PCB005

15) BIG BALL ELEVATOR PART

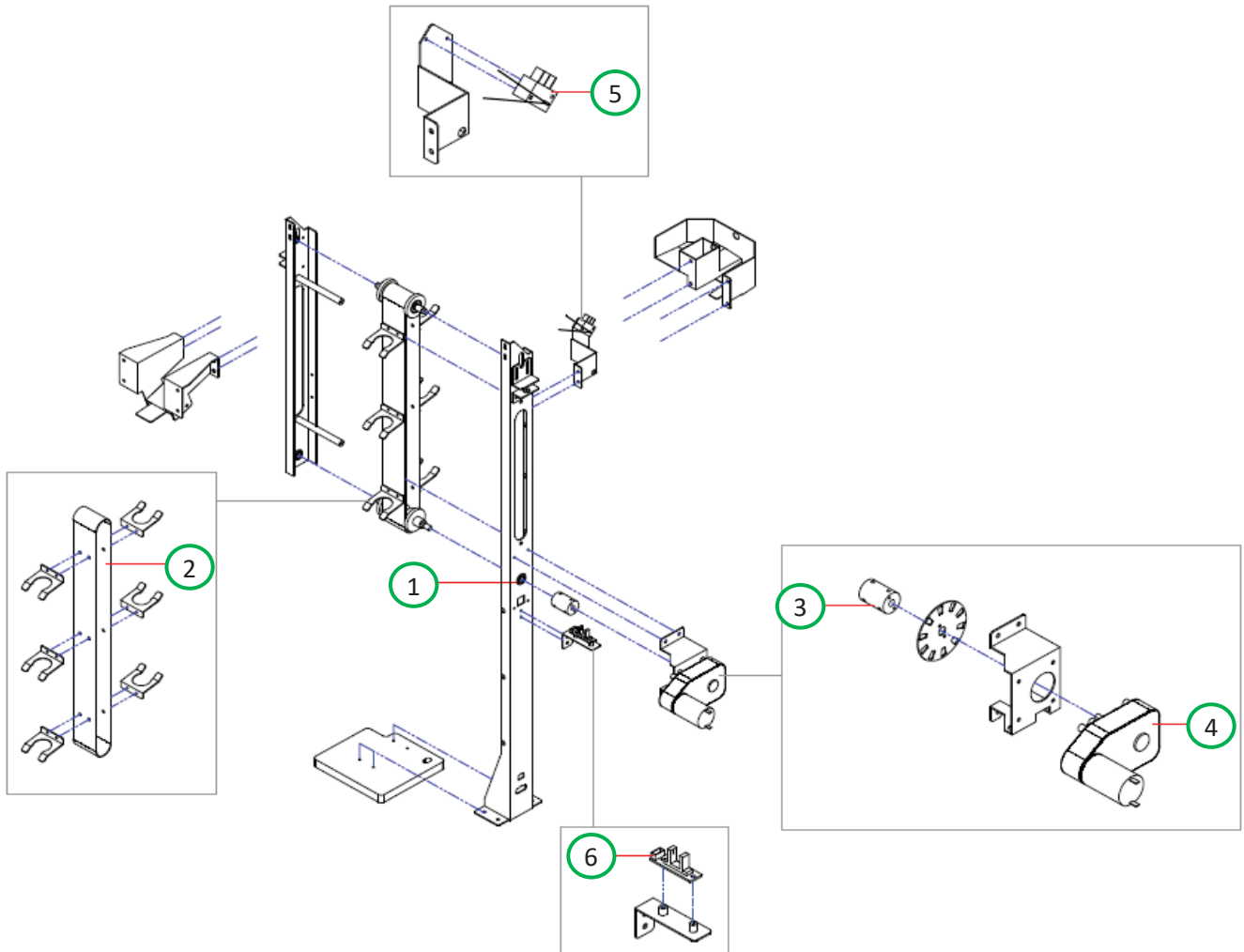

NO	PART NAME	SPEC	Q'TY	CODE NO
1	BEARING	F689ZZ	1	MZZZ0BEA068
2	BIG BALL ELEVATOR BELT	PVC1.4Tx50Wx954.2L	1	MZZZ0BEL047
3	COUPLING	CR050	1	AZZZ0COP002
4	MOTOR	KGV2-0200-3657U1	1	MZZZ0MOT161
5	MICRO SWITCH	CNR-05H-03 ZIPPY	2	MELE0MIC002
6	PHOTO-INT1 PCB	ANGLE TYPE	2	AZZZ0PCB103

16) BIG BALL INLET GUIDE RAIL PART

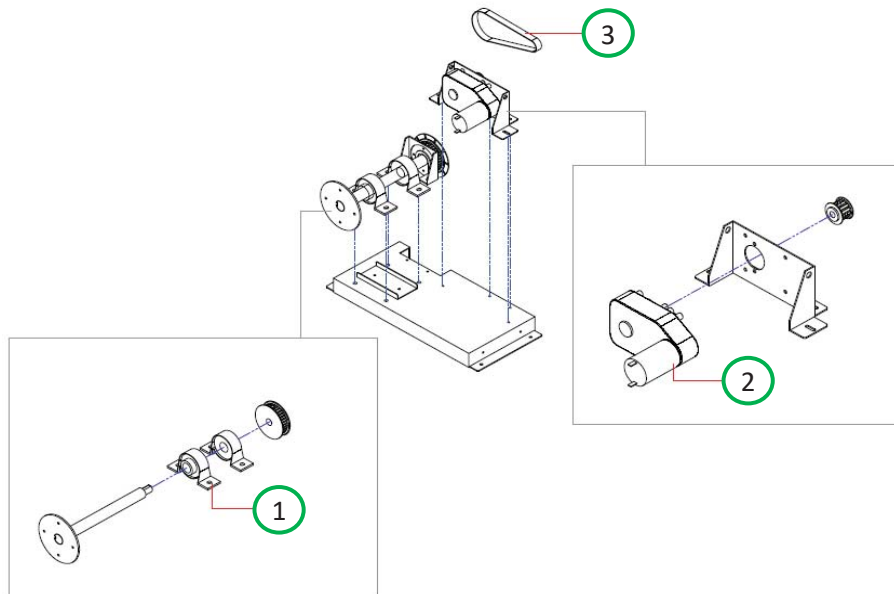

NO	PART NAME	SPEC	Q'TY	CODE NO
1	BEARING	SAPP204	2	MZZZ0BEA089
2	MOTOR	KGV2-0500-3657U1_F TYPE	1	MZZZ0MOT160
3	TARGET WHEEL MOTOR TIMMING BELT	148XL	1	MSAWOZZZ004

17) TARGET WHEEL PART

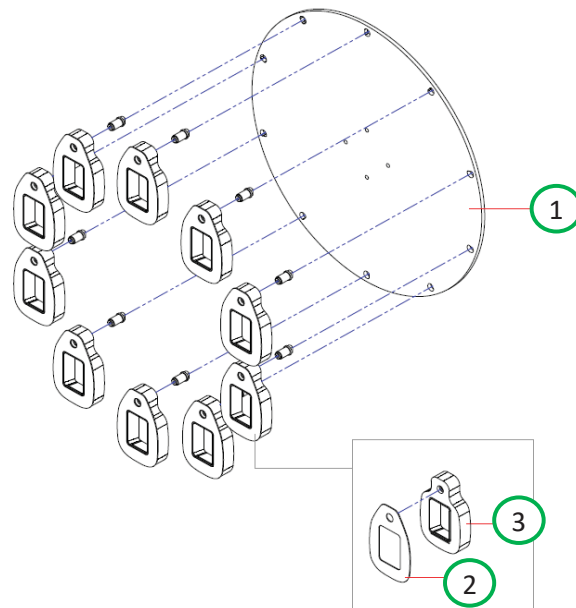

NO	PART NAME	SPEC	Q'TY	CODE NO
1	TARGET WHEEL BASE ACRYL	ACRYL 5T	1	MAV20ACR008
2	TARGET COVER ACRYL	PC 1T	10	AAV20ACP022
3	TARGET MOLD	ABS 2T	10	MAV20PLA001

18) SLOT WHEEL PART

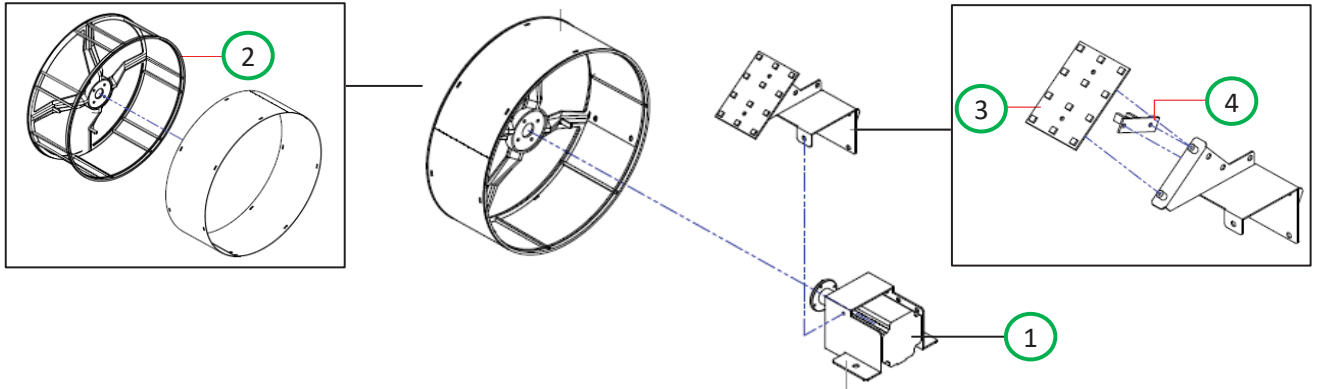

NO	PART NAME	SPEC	Q'TY	CODE NO
1	STEPPING MOTOR	4S56Q-08576S	1	MZZZ0MOT167
2	SLOT WHEEL MOLD	-	1	MAV20PLA002
3	NEW BONUS SPIN LED PCB ASS'Y	-	1	AAV20PCB003
4	PHOTO INT01 PCB ASS'Y	-	1	ACIR0PCB011

19) TARGET WHEEL DECO COVER PART

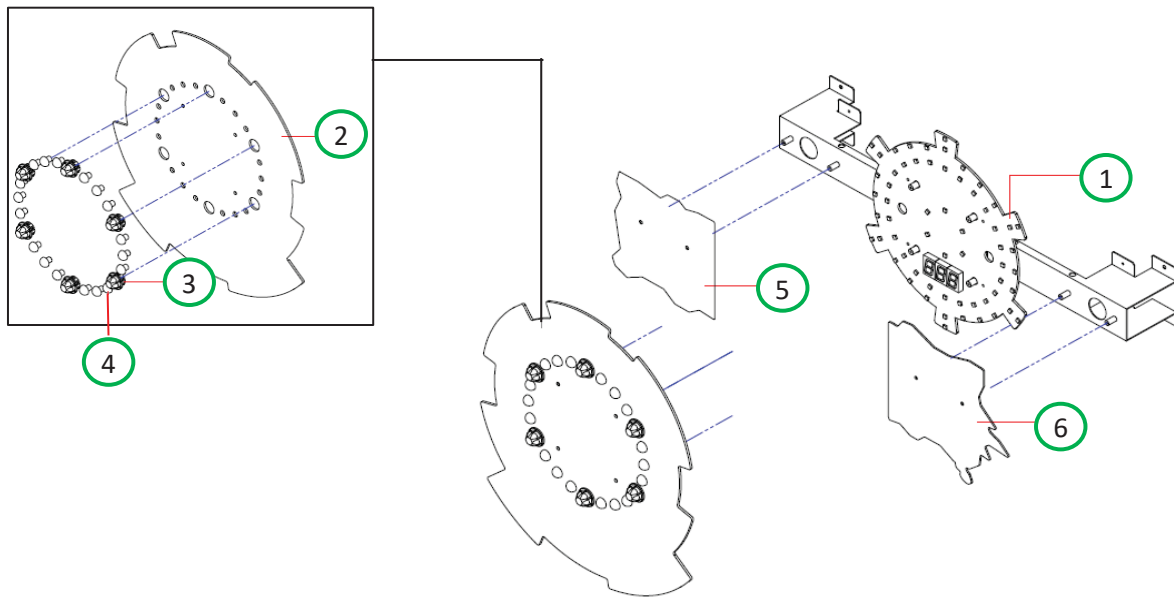

NO	PART NAME	SPEC	Q'TY	CODE NO
1	TARGET WHEEL LED PCB ASS'Y	-	1	AAV20PCB004
2	TARGET WHEEL DECO COVER-A	ACRYL 3T	1	AAV10ACP016
3	LED CAP	Φ20 LED CAP	1	MZZZ0PLA037
4	LED CAP	Φ15 LED CAP	1	MWOL0PLA002
5	TARGET WHEEL DECO COVER-B	PET 1T	1	AAV10ACP013
6	TARGET WHEEL DECO COVER-C	PET 1T	1	AAV10ACP014

20) TOKEN BRIDGE PART

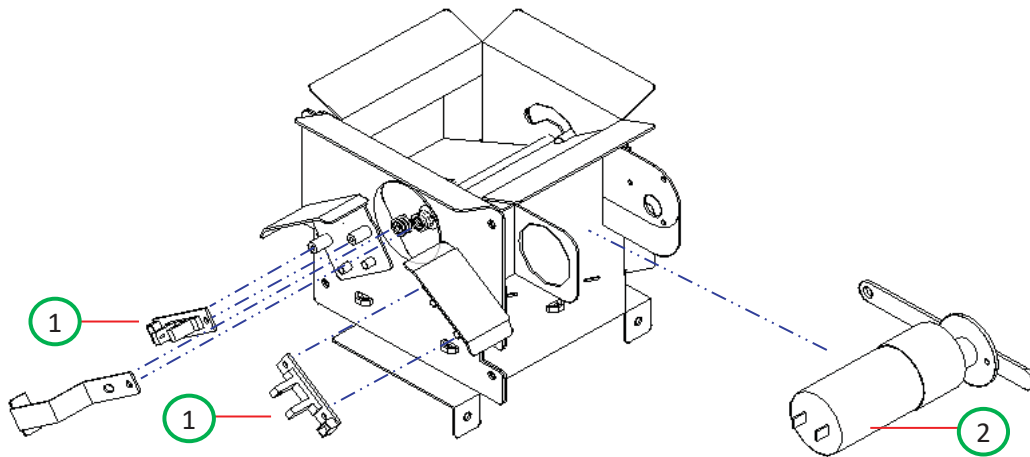

NO	PART NAME	SPEC	Q'TY	CODE NO
1	PHOTO INT-1 PCB ASS'Y	-	2	ACIR0PCB011
2	MOTOR	KGC-0240-3448S2_24V	1	MZZZ0MOT173

21) COIN SHOOTING RAIL PART

22) TOP LED LAMP PART

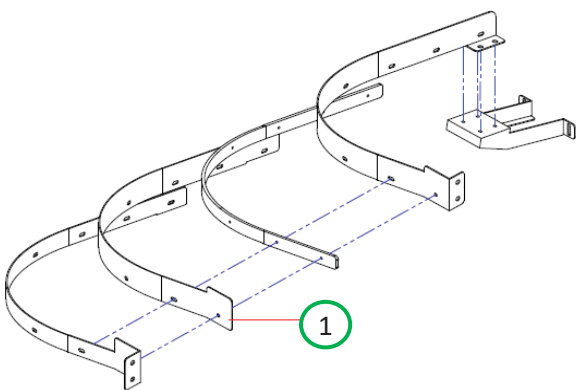

NO	PART NAME	SPEC	Q'TY	CODE NO
1	COIN SHOOTER RAIL OUTER COVER	PET 1T	1	MAV20ACR051
2	LED BAR PCB ASS'Y	460 MM	1	AZZZ0PCB124

23) MEDAL ROLLER PART

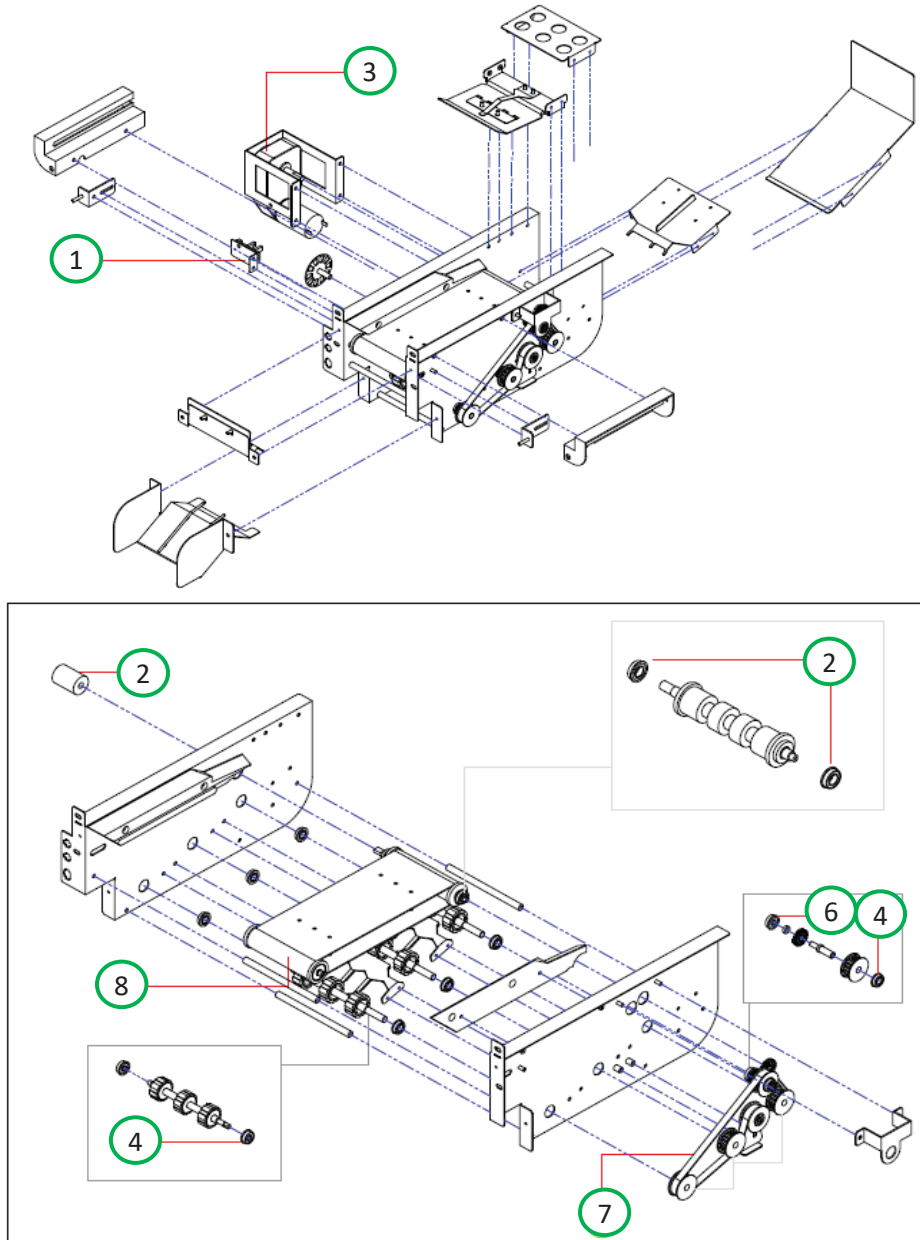

* CARD VERSION ONLY

NO	PART NAME	SPEC	Q'TY	CODE NO
1	PHOTO INT-1 PCB ASS'Y	ANGLE TYPE	1	AZZZ0PCB103
2	COUPLING	CR050	1	AZZZ0COP002
3	MOTOR	KGV-0060-ND3657 U2	1	MZZZ0MOT168
4	BEARING	F688ZZ	7	MZZZ0BEA076
5	BEARING	F689ZZ	2	MZZZ0BEA068
6	BEARING	F606ZZ	1	MZZZ0BEA073
7	TIMMING BELT	194XL(WI9.5)	1	MZZZ0BEL054
8	MEDAL ROLLER CONVEYER	L:538.5 x W:100	1	MAV20RUB001

24) BIG WHEEL PART

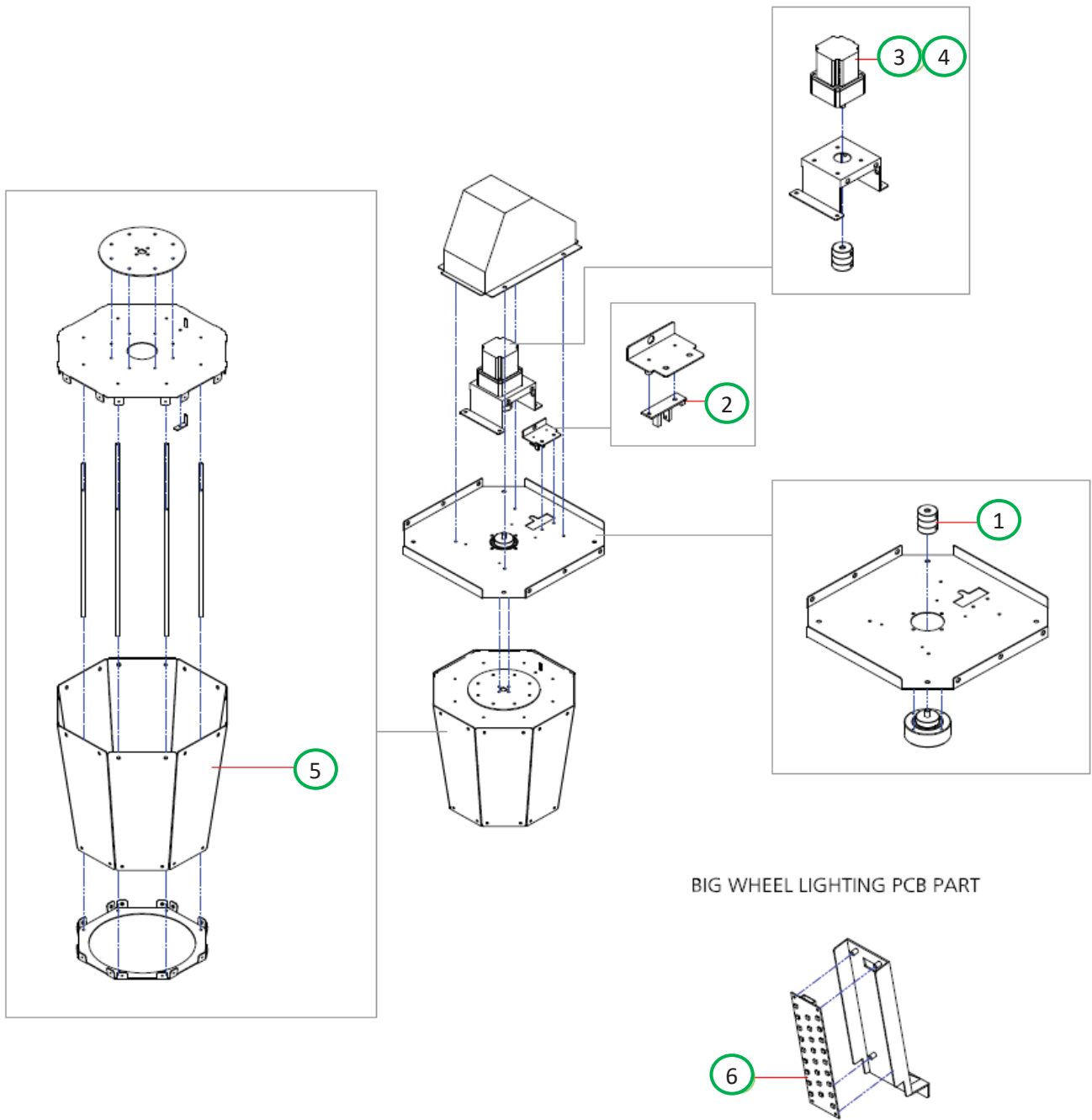

NO	PART NAME	SPEC	Q'TY	CODE NO
1	COUPLING	JOC30	1	MZZZ0COP002
2	PHOTO INT1 PCB ASS'Y	-	1	ACIR0PCB011
3	STEPPING MOTOR	4S56Q-P025545G	1	MZZZ0MOT166
4	GEAR HEAD	K6G3C	1	MWIC0PAR028
5	BIG WHEEL OUTER DECO COVER	PET 1T	8	AAV20ACP026~35
6	SPOT LED PCB ASS'Y	-	1	ABAP90PCB008

25) BIG WHEEL WIN LED PART

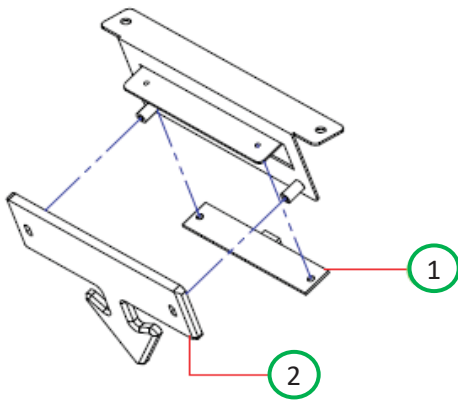

26) BONUS WIN OUTLET COVER ACRYL PART

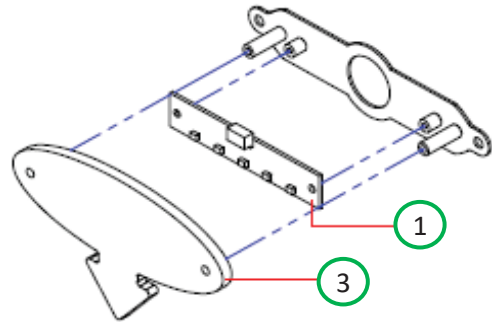

NO	PART NAME	SPEC	Q'TY	CODE NO
1	LED PCB ASS'Y	-	1	AMUM0PCB005
2	BIG WHEEL WIN LED ACRYL	ACRYL 5T	1	AAV10ACP011
3	BOUNS WIN OUTLET COVER ACRYL	ACRYL 5T	1	AAV20ACP023, AAV20ACP024

* 023: STONE, 024:TOKEN

27) GAUNTLET DECO PART

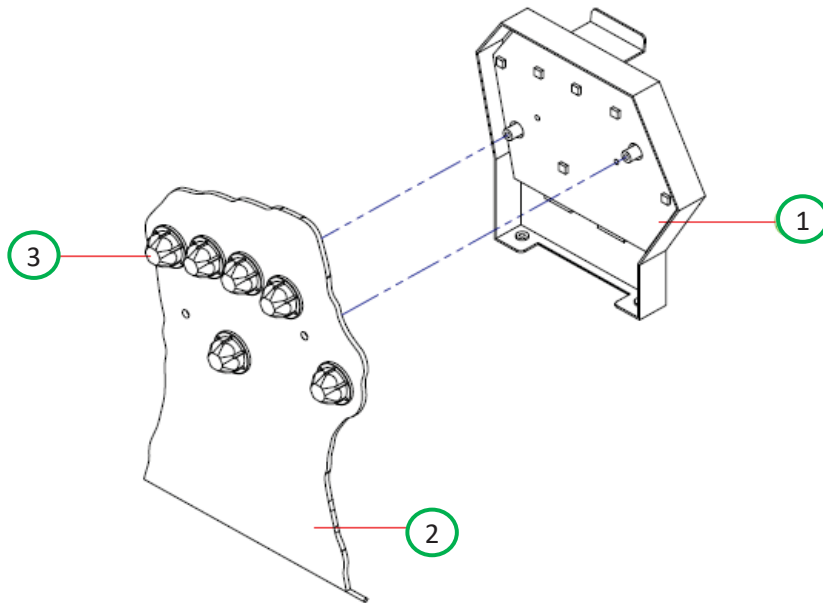

NO	PART NAME	SPEC	Q'TY	CODE NO
1	GAUNTLET LED PCB ASS'Y	-	1	AAV20PCB002
2	GAUNTLET FRONT COVER ACRYL	PET 2T	1	AAV10ACP007
3	LED CAP	Φ20 LED CAP	6	MAZZZ0PLA037

28) CARD DISPENSER PART

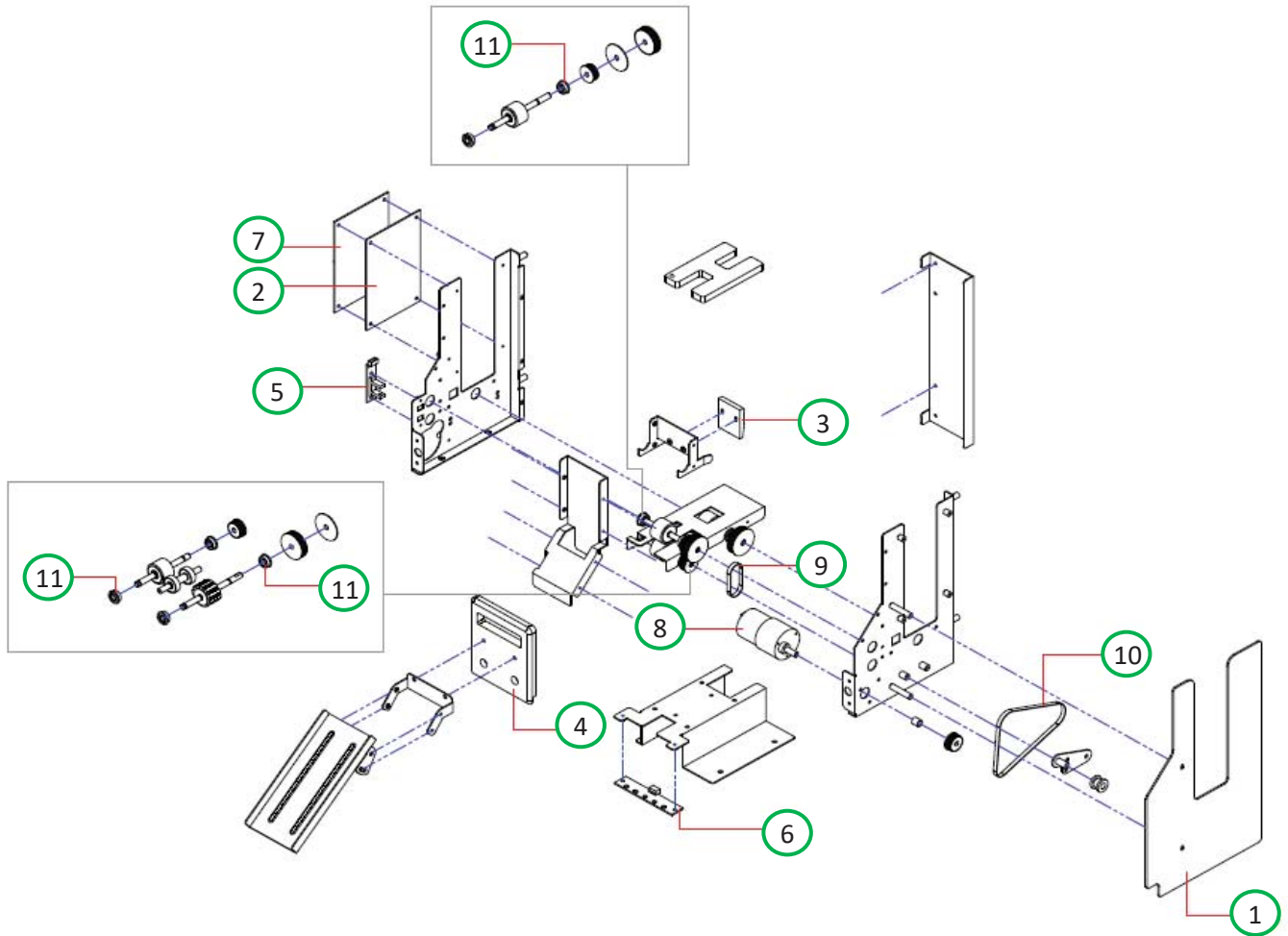

* CARD VERSION ONLY

NO	PART NAME	SPEC	Q'TY	CODE NO
1	CARD DISPENSER DECO COVER	PET 1T	1	AAV10ACP017
2	CARD DISPENSER IO PCB COVER	PET 1T	1	AAV20ACP041
3	CARD OUTLET GUIDE BLOCK	-	1	MZZZ0PLA042
4	CARD DISPENSER FRONT MASK MOLD	-	1	MDCC0PLA009
5	PHOTO INT-1 PCB ASS'Y	ANGLE TYPE	1	AZZZ0PCB103
6	LED PCB ASS'Y	-	1	AMUM0PCB005
7	CARD DISPENSER IO PCB ASS'Y	-	1	ASBP0PCB008
8	MOTOR	KGC-3429	1	MZZZ0MOT089
9	CARD DISPENSER TIMMING BELT-A	52MXL	1	MZZZ0BEL018
10	CARD DISPENSER TIMMING BELT-B	147MXL	1	MZZZ0BEL019
11	BEARING	F686ZZ	6	MZZZ0BEA094

29) FRONT DOOR PART

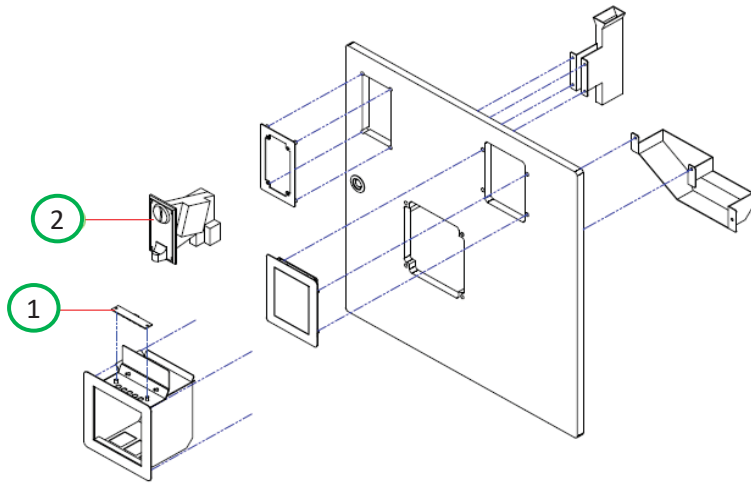

30) TICKET DOOR PART

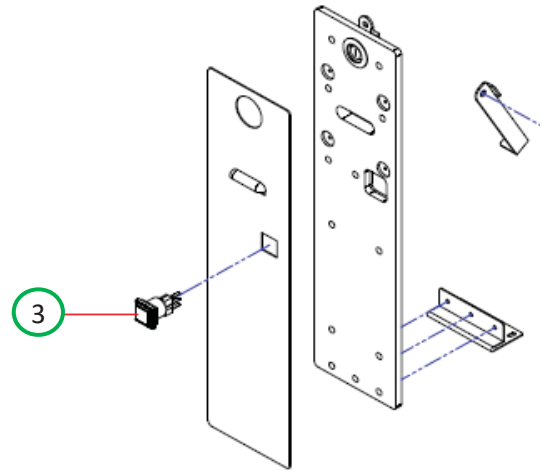

NO	PART NAME	SPEC	Q'TY	CODE NO
1	LED PCB ASS'Y	-	1	AMUM0PCB005
2	COIN SELECTOR(OPTION)	-	1	-
3	TICKET BUTTON	AM1PB-26SH R12D	1	MMUM0BUT002

31) SPEAKER BOX - L, R PART

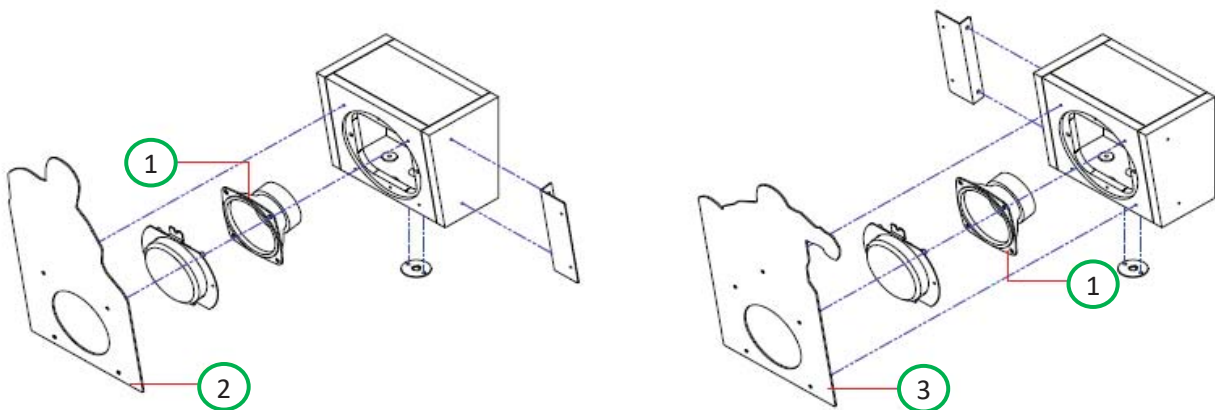

NO	PART NAME	SPEC	Q'TY	CODE NO
1	SPEAKER	MID4.5+TW1/2 8OHM	1	MZZZ0SPE021
2	SP BOX DECO COVER-L	PET 2T	1	AAV10ACP005
3	SP BOX DECO COVER-R	PET 2T	1	AAV10ACP006

32) BUTTON PANEL PART

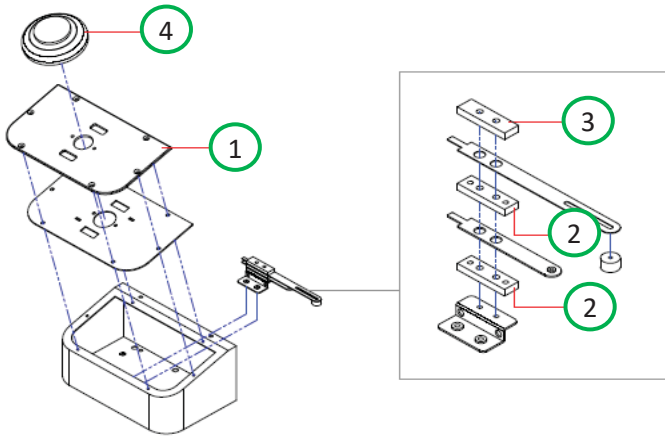

33) FRONT DOOR GLASS PART

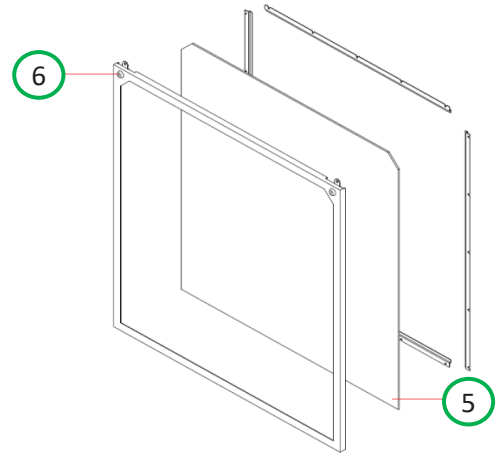

NO	PART NAME	SPEC	Q'TY	CODE NO
1	BUTTON ACRYL	ACRYL 3T	1	AAV20ACP007
2	TABLE TILT BLOCK-A	ACRYL 8T	1	MAV20ACR054
3	TABLE TILT BLOCK-B	ACRYL 8T	1	MAV20ACR055
4	BUTTON ASS'Y	CL-2020 65 WITH LED	1	AZZZ0BUT009
5	FRONT GLASS	GLASS 5T	1	MAV10GLA001
6	KEY ASS'Y	7001	2	MZZZ0KEY076

34) FRONT, REAR ELEVATOR HOPPER PART

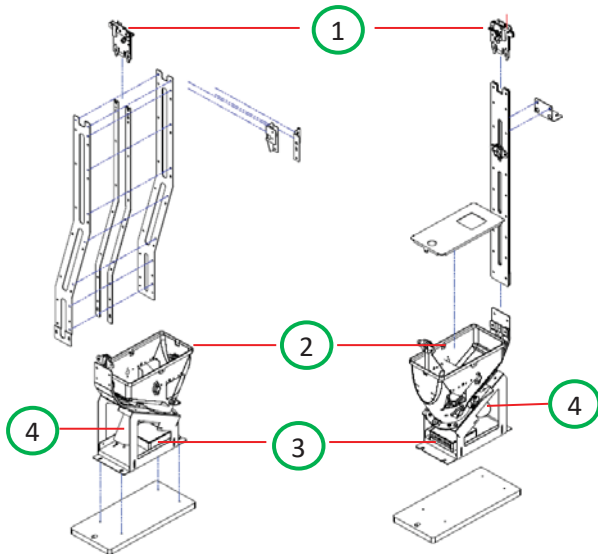

35) THANOS DECO PART

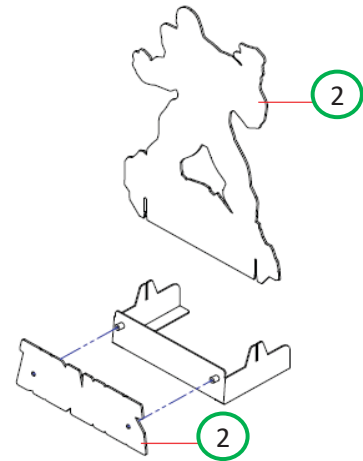

* NON CARD VERSION ONLY

NO	PART NAME	SPEC	Q'TY	CODE NO
1	ELEVATOR SENSOR	-	1	AZZZ0PCB173
2	ELEVATOR HOPPER BODY ASS'Y	-	1	AAV20ASS037
3	ELEVATOR HOPPER PCB ASS'Y	-	1	AZZZ0PCB143
4	MOTOR	-	1	MZZZ0ELH040
5	THANOS DECO FRONT COVER	PET 1T	1	AAV20ACP050
6	THANOS DECO MAIN COVER	PET 2T	1	AAV20ACP051

9 PCB CONNETCOR LOCATION

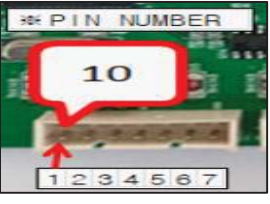
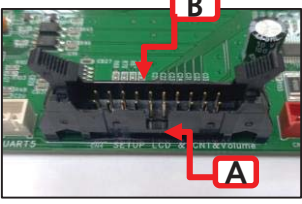
1	2	pin description
		<p>1. The arrow point means the contact pin number 1. 2. direction of Hirose connector</p>

1) MAIN PCB ASS'Y

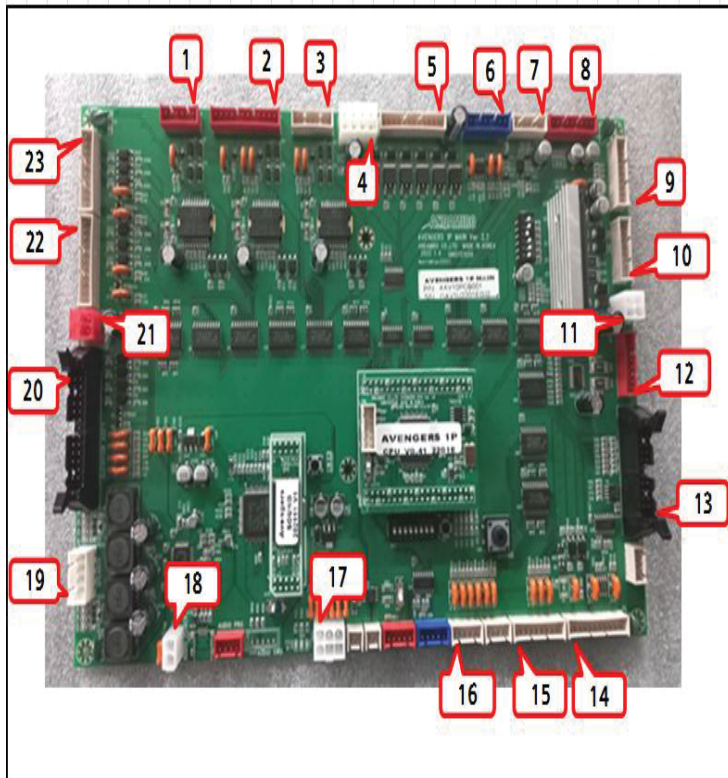

NO	FUNCTION	LOCATION	PIN
1	CONVEYER(MEDAL ROLLER)	CN5	6
2	BIG BALL & BALL IN SENSOR	CN16	12
3	TOKEN BRIDGE	CN15	7
4	ADDITION POWER 12V	CN25	8
5	WHITE LED(MAIN CONTROL)	CN12	2
6	TICKET DISPENSER	CN22	8
7	CARD DISPENSER	CN21	6
8	BUTTON RGB LED	CN6	9
9	FND & WHEEL, GAUNTLET LEI	CN7	11
10	BIG WHEEL MOTOR & SENSO	CN17	8
11	STEP POWER 24V	CN26	4
12	REEL MOTOR & SENSOR	CN18	8
13	SETUP LCD & COUNTER	CN4	20
14	MEDAL IN SENSOR	CN11	9
15	COIN & BILL & BUTTON	CN23	11
16	TILT(REAR, BUTTON)	CN13	5
17	MAIN POWER 5V, 12V	CN24	6
18	AUDIO POWER 12V	CN28	2
19	SPEAKER	CN31	4
20	FRONT & REAR ELV HOPPWER	CN10	26
21	HOPPER POWER 24V	CN26	4
22	WHEEL MOTOR	CN20	11
23	PUSHER MOTOR & SENSOR	CN19	10

POWER SUPPLY

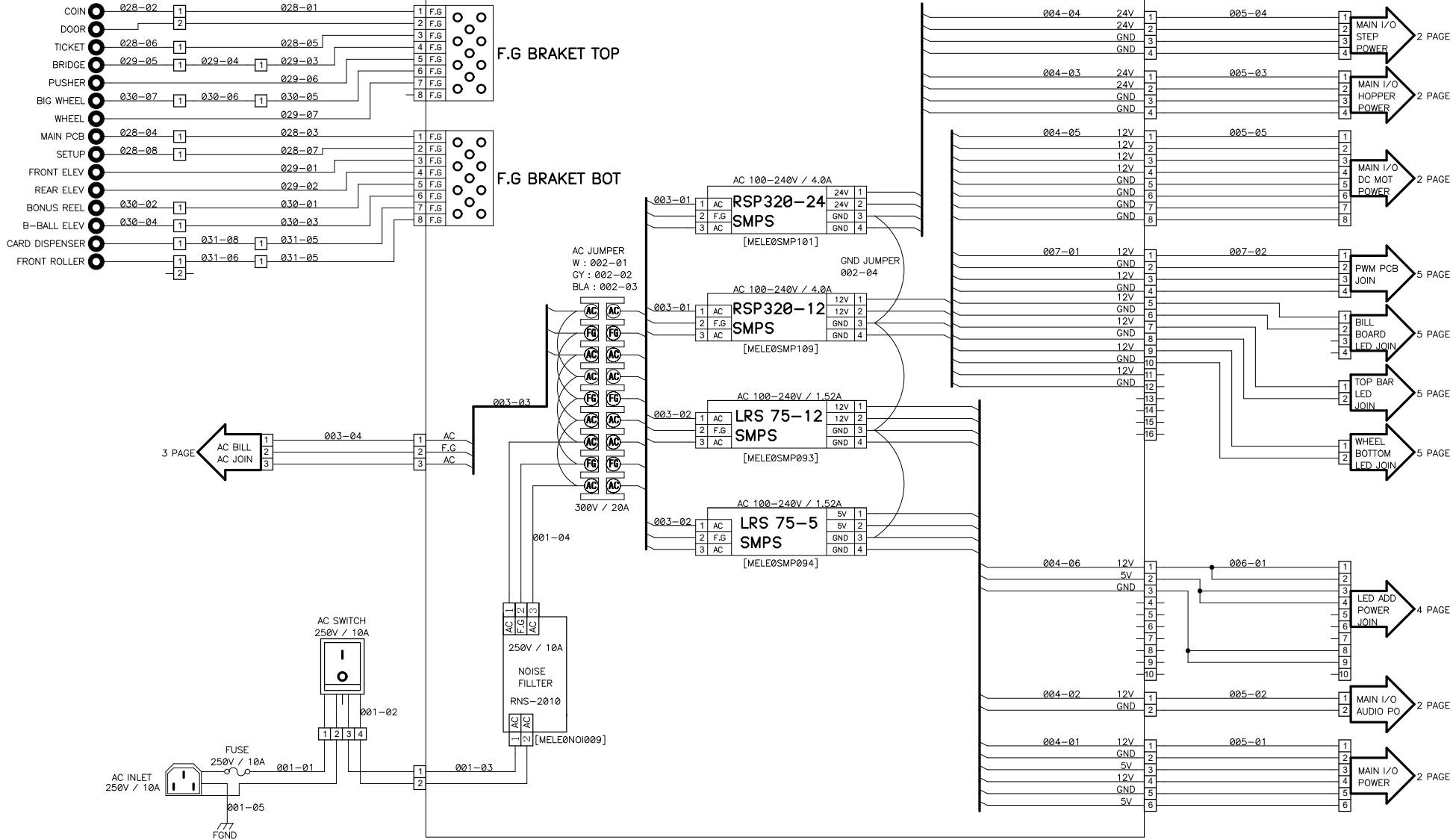

REPRODUCTION, DISTRIBUTION AND UTILIZATION OF THIS DOCUMENT AS WELL AS COMMUNICATION OF ITS CONTENTS TO OTHERS WITHOUT EXPRESS AUTHORIZATION PROHIBITED. OFFENDERS WILL BE HELD LIABLE FOR THE PAYMENT OF DAMAGES. ALL RIGHT RESERVED. COPYRIGHT (c) ANDAMIRO

(복제, 배포 및 사용은 물론, 명시적 허가 없이는 라이에게 내용을 전달할 수 없으며 위반자는 손해 배상 책임을 집니다.)

DEPARTMENT	DRAWN BY	CHECKED BY	APPROVED BY	ITEM	AVENGERS 1P
H/W	K.H.LIM			PAGE	2021.11.30
ANDAMIRO				DATE	1 PAGE

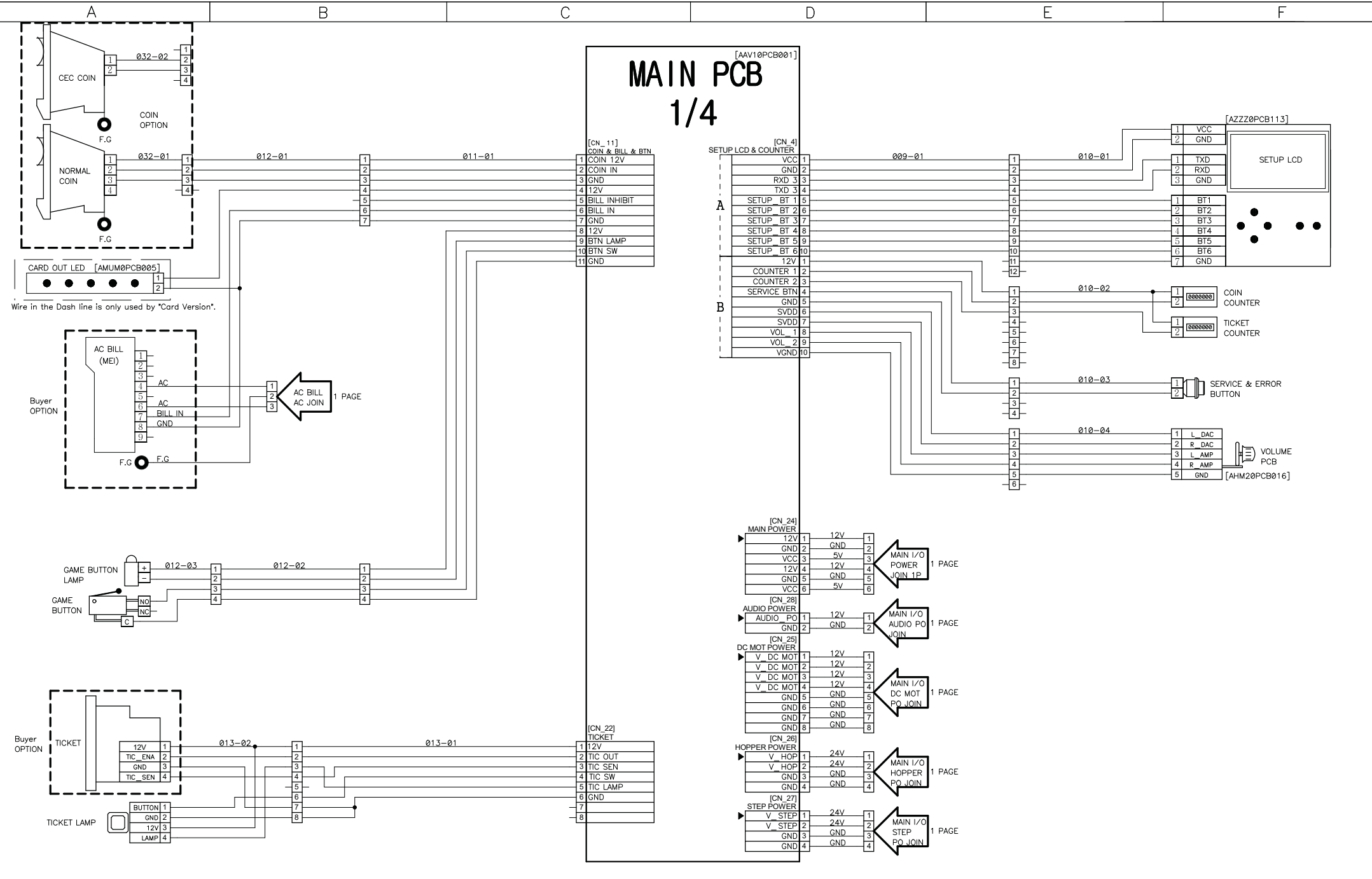

REPRODUCTION, DISTRIBUTION AND UTILIZATION OF THIS DOCUMENT AS WELL AS COMMUNICATION OF ITS CONTENTS TO OTHERS WITHOUT EXPRESS AUTHORIZATION PROHIBITED. OFFENDERS WILL BE HELD LIABLE FOR THE PAYMENT OF DAMAGES. ALL RIGHT RESERVED. COPYRIGHT (c) ANDAMIRO

(복제, 배포 및 사용은 물론, 명시적 허가 없이는 타인에게 내용을 전달할 수 없으며 위반자는 손해 배상 책임을 집니다.)

DEPARTMENT	DRAWN BY	CHECKED BY	APPROVED BY	ITEM	AVENGERS 1P
H/W	K.H.LIM			PAGE	2021.11.30
				DATE	2 PAGE

MAIN PCB 2/4

[AAV10PCB001]

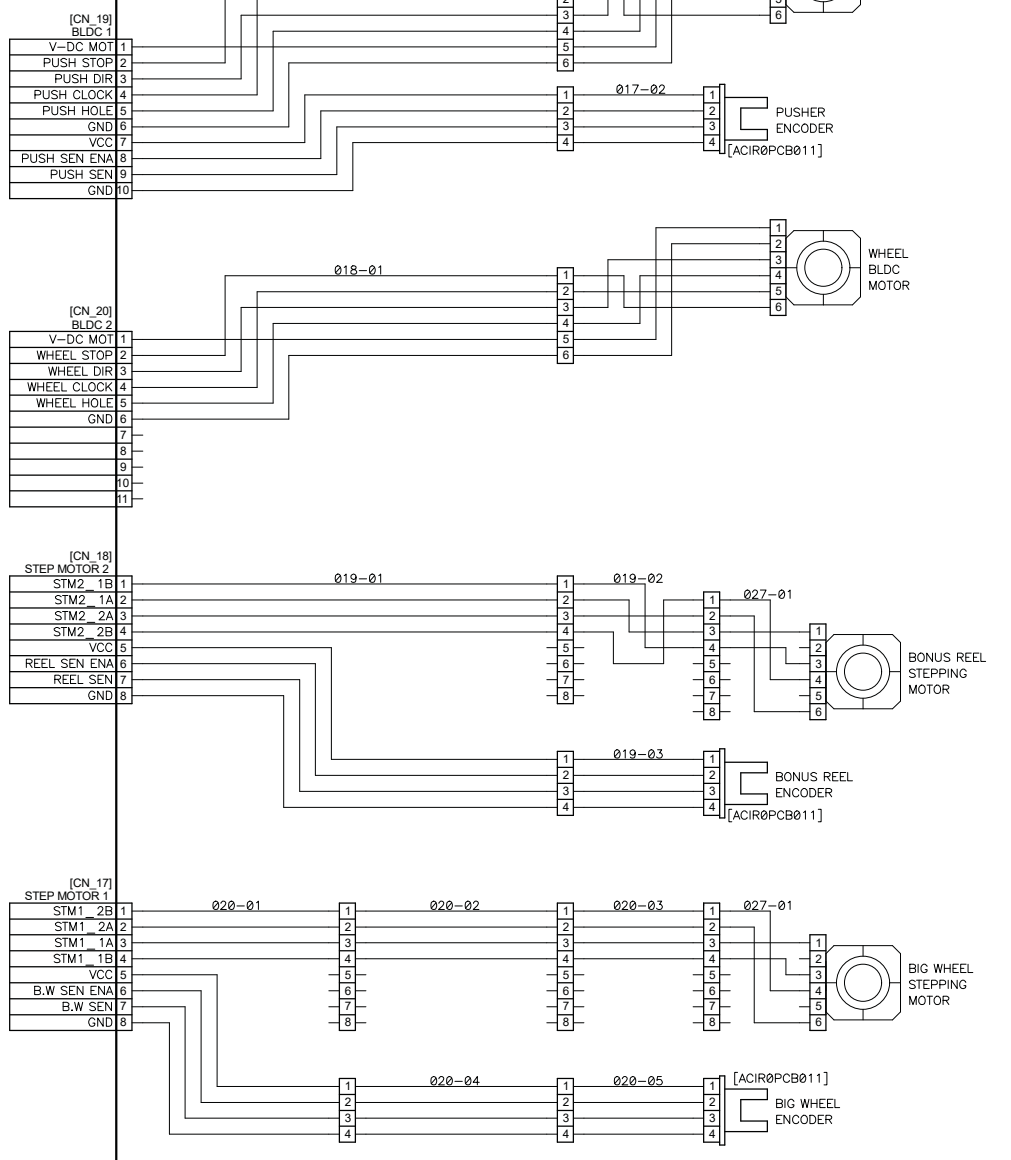
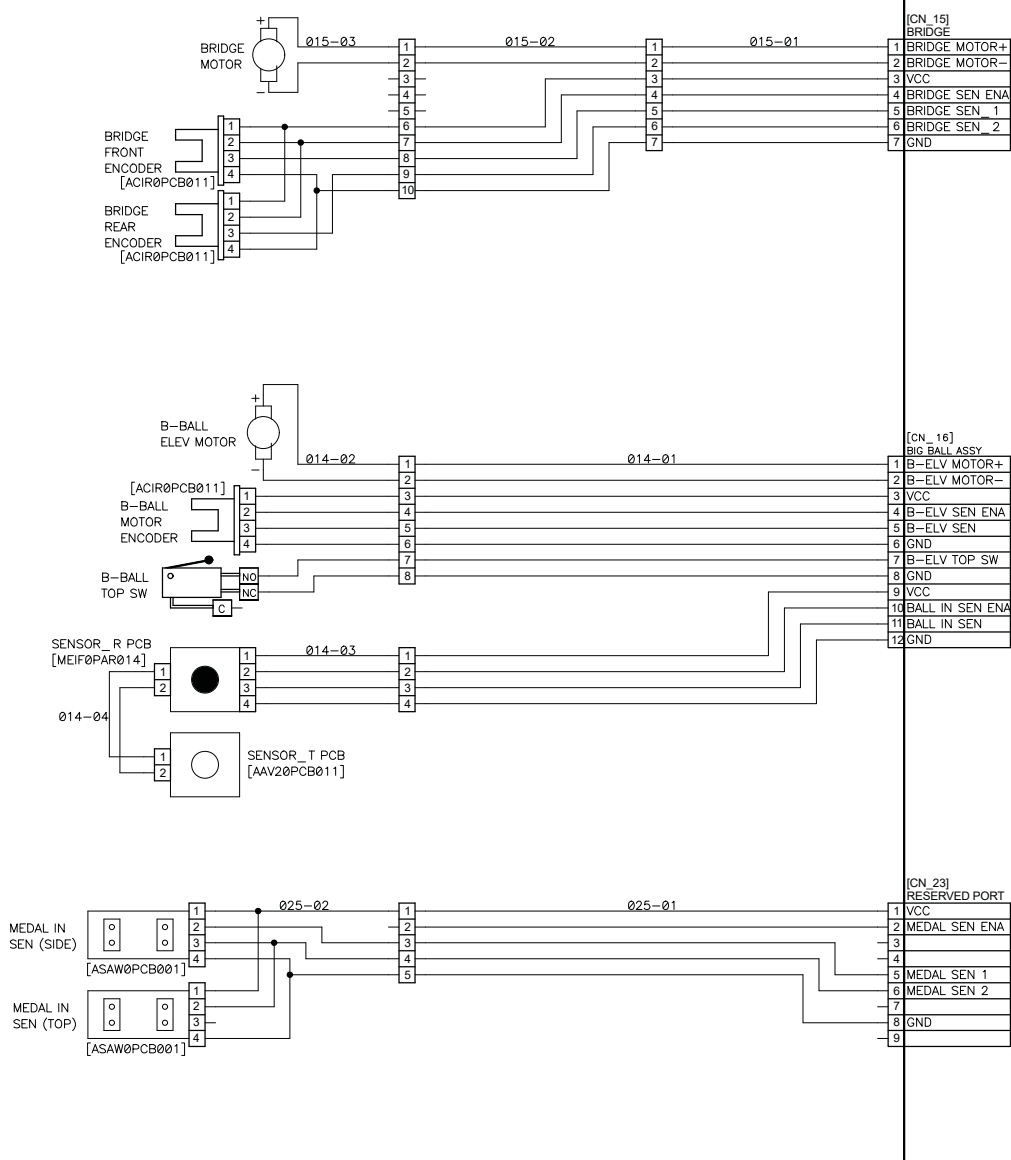

REPRODUCTION, DISTRIBUTION AND UTILIZATION OF THIS DOCUMENT AS WELL AS COMMUNICATION OF ITS CONTENTS TO OTHERS WITHOUT EXPRESS AUTHORIZATION PROHIBITED. OFFENDERS WILL BE HELD LIABLE FOR THE PAYMENT OF DAMAGES. ALL RIGHT RESERVED. COPYRIGHT (c) ANDAMIRO

(복제, 배포 및 사용은 물론, 명시적 허가 없이는 타인에게 내용을 전달할 수 없으며 위반자는 손해 배상 책임을 집니다.)

DEPARTMENT	DRAWN BY	CHECKED BY	APPROVED BY	ITEM	AVENGERS 1P
H/W	K.H.LIM			PAGE	2021.11.30
				DATE	3 PAGE



MAIN PCB 3/4

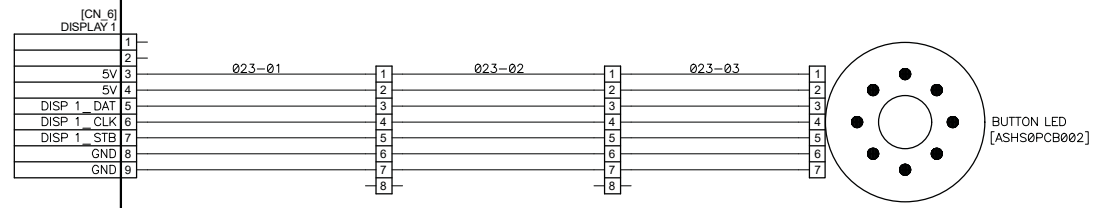
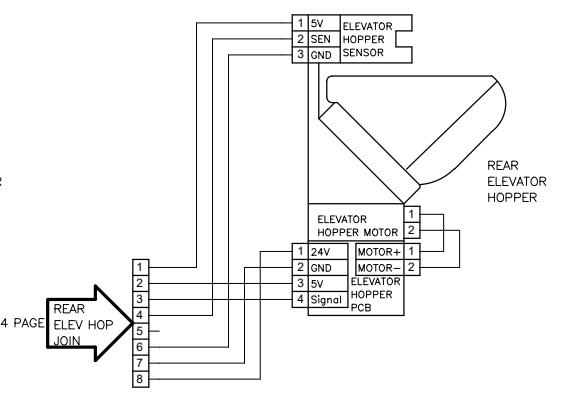
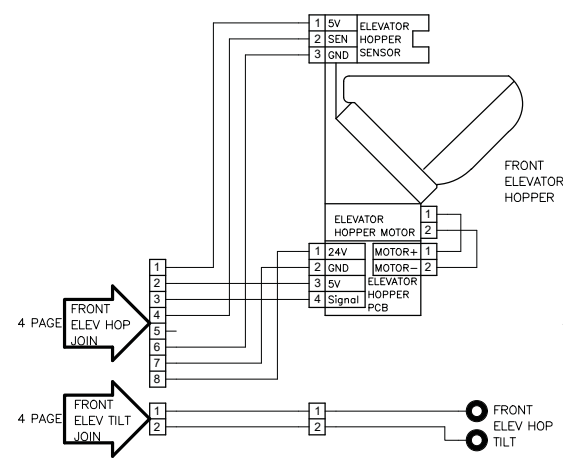
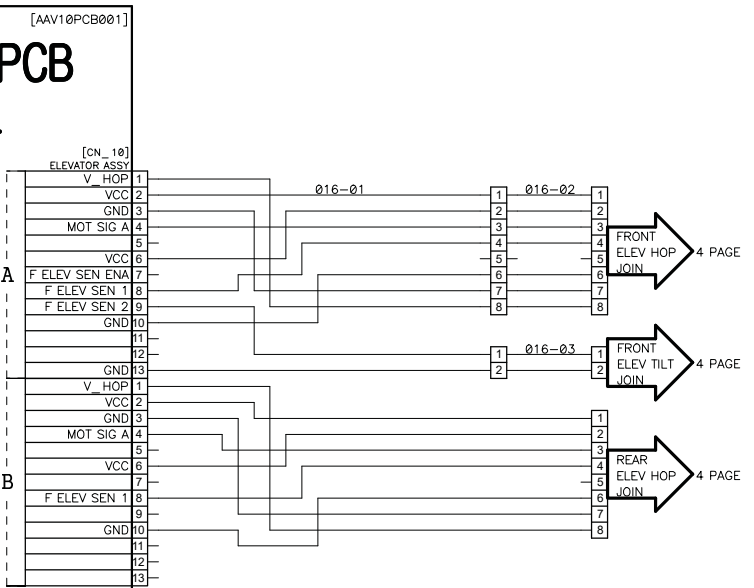

CH NO.	DIRECTION
DISPLAY 1	BUTTON -> END
DISPLAY 2	TICKET FND -> TOKEN FND -> WHEEL LED -> GAUNTLET LED -> END

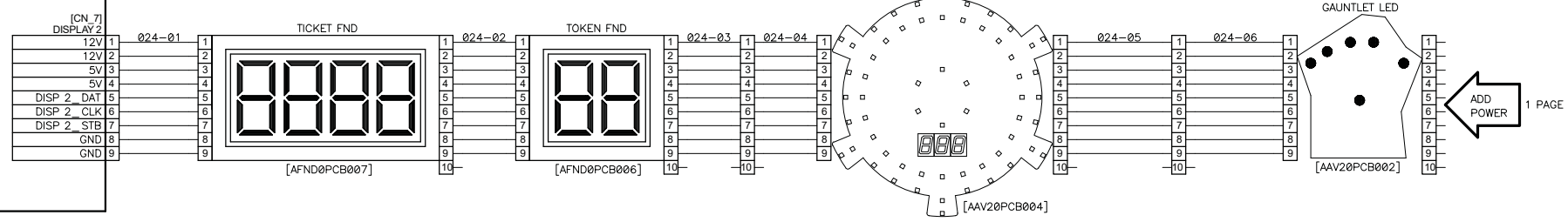

REPRODUCTION, DISTRIBUTION AND UTILIZATION OF THIS DOCUMENT AS WELL AS COMMUNICATION OF ITS CONTENTS TO OTHERS WITHOUT EXPRESS AUTHORIZATION PROHIBITED. OFFENDERS WILL BE HELD LIABLE FOR THE PAYMENT OF DAMAGES. ALL RIGHT RESERVED. COPYRIGHT (c) ANDAMIRO

(복제, 배포 및 사용은 물론, 명시적 허가 없이는 타인에게 내용을 전달할 수 없으며 위반자는 손해 배상 책임을 집니다.)

DEPARTMENT	DRAWN BY	CHECKED BY	APPROVED BY	ITEM	AVENGERS 1P
H/W	K.H.LIM			PAGE	2021.11.30
				DATE	4 PAGE



MAIN PCB 4/4

[AAV10PCB001]

Component in the Dash line is only used by "Card Version".

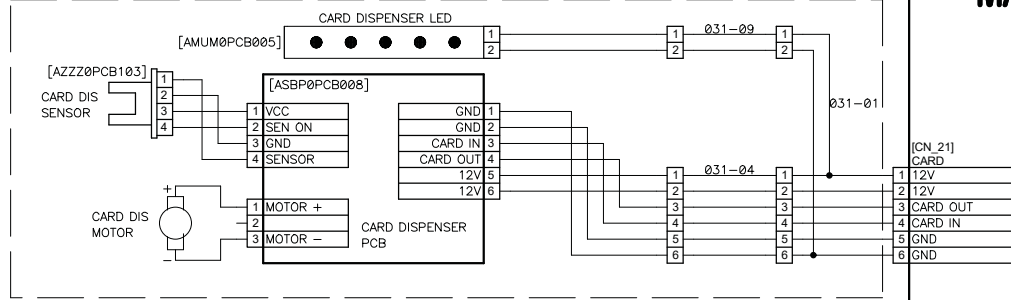

Component in the Dash line is only used by "Card Version".

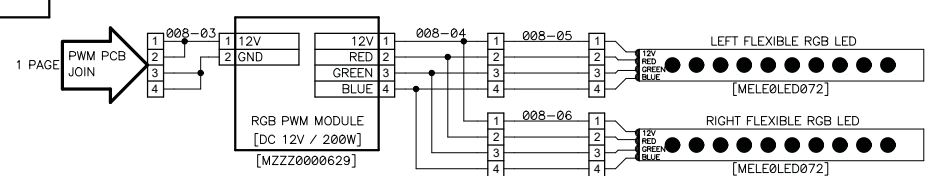
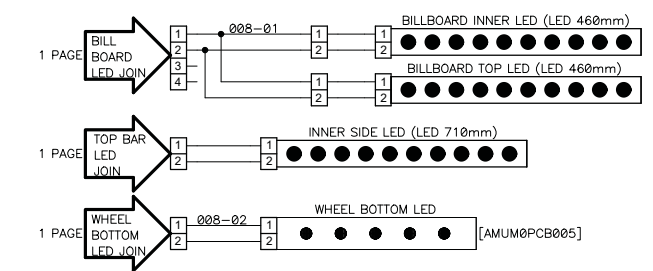
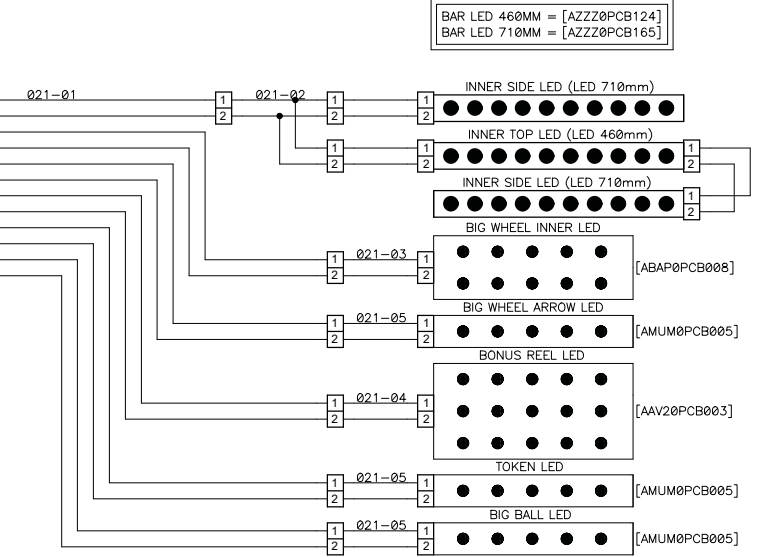
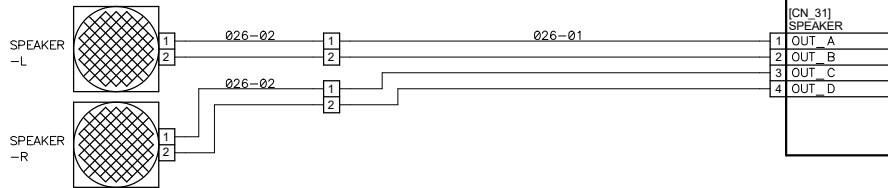
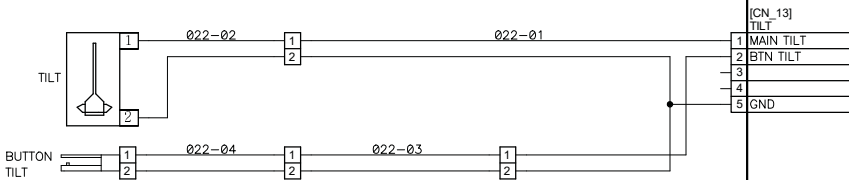
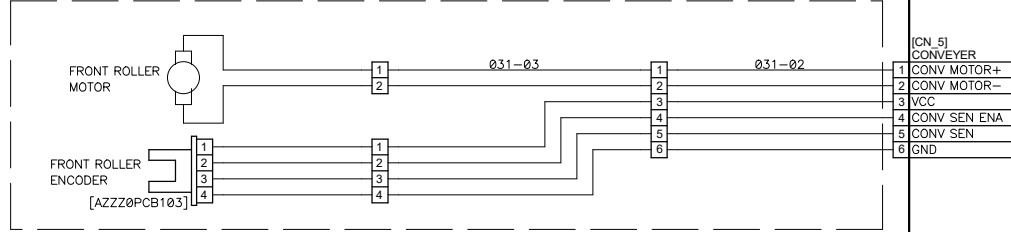

REPRODUCTION, DISTRIBUTION AND UTILIZATION OF THIS DOCUMENT AS WELL AS COMMUNICATION OF ITS CONTENTS TO OTHERS WITHOUT EXPRESS AUTHORIZATION PROHIBITED. OFFENDERS WILL BE HELD LIABLE FOR THE PAYMENT OF DAMAGES.ALL RIGHT RESERVED. COPYRIGHT (c) ANDAMIRO

(복제, 배포 및 사용은 물론, 명시적 허가 없이는 라이에게 내용을 전달할 수 없으며 위반자는 손해 배상 책임을 집니다.)

DEPARTMENT	DRAWN BY	CHECKED BY	APPROVED BY	ITEM	AVENGERS 1P
H/W	K.H.LIM			PAGE	2021.11.30
ANDAMIRO				DATE	5 PAGE -END-



ANDAMIRO WARRANTY POLICY



Andamiro warrants to the original purchaser that all of its products will be free from defects in material and workmanship.

Andamiro warrants the parts from date of shipment as follows.

- **One Year Limited Warranty : Electronic Boards**
- **6 Months Limited Warranty : Moving Parts**

For any key components within the warranty period, Andamiro will repair or replace defective components free of charge.

When placing a warranty request, the customer is requested to furnish the following information:

1. Name of the game.
2. Serial Number of the game.
3. A Detailed Description of the defect/s experienced.

This warranty does not apply to the defects caused due to misuse or abuse of the product.

Any alterations made to game or game parts will void this warranty.

For warranty details on our product range please visit our website, www.andamiro.com.

ANDAMIRO CO., LTD.
www.andamiro.com





ANDAMIRO CO., LTD.

TEL : 82-31-909-2123~5

[ADDRESS OFFICE] 704-1 Techno Town, 138, Ilsan-ro, Ilsandong-gu, Goyang-si,
Gyeonggi-do, 10442 Rep of Korea

[FACTORY] 72 Nocheom-gil, Ilsandong-gu, Goyang-si, Gyeonggi-do, 10432 Rep of Korea

USA BRANCH

ANDAMIRO USA CORP.

TEL : 1-310-767-5800

[ADDRESS] 2222 Century Cir, Irving TX 75062 U.S.A

Homepage <http://www.andamiro.com/>